

# Adept Lynx Platform

## User's Guide

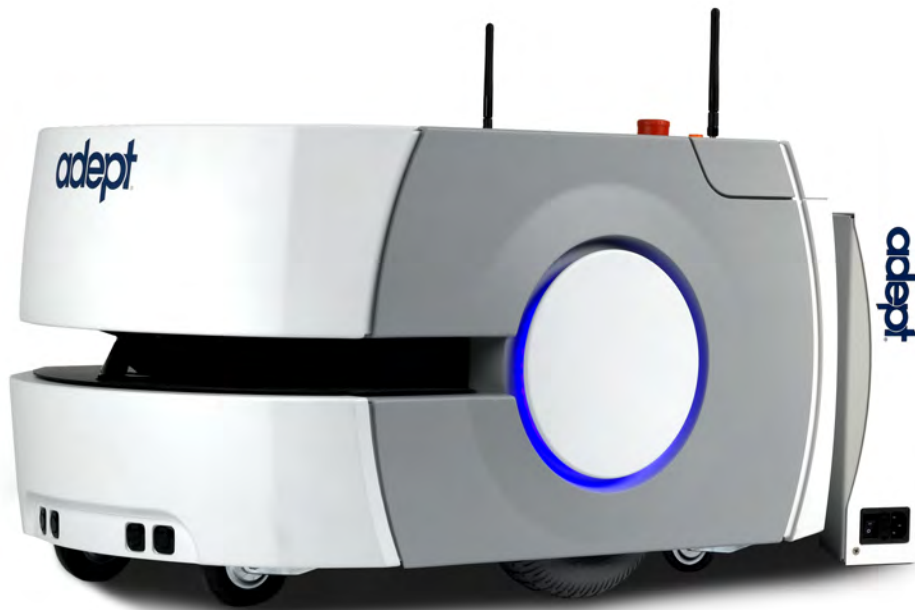

**adept**<sup>®</sup>



# Adept Lynx Platform

## User's Guide



11970-000 Rev B  
March, 2014



5960 Inglewood Drive • Pleasanton, CA 94588 • USA • Phone 925.245.3400 • Fax 925.960.0452  
Revierstraße 5 44379 Dortmund Germany • Phone +49.231.75.89.40 • Fax +49.231.75.89.450  
Block 5000 Ang Mo Kio Avenue 5 • #05-12 Techplace II • Singapore 569870 • Phone +65.6755 2258 • Fax +65.6755 0598

---

## Copyright Notice

---

The information contained herein is the property of Adept Technology, Inc., and shall not be reproduced in whole or in part without prior written approval of Adept Technology, Inc. The information herein is subject to change without notice and should not be construed as a commitment by Adept Technology, Inc. The documentation is periodically reviewed and revised.

Adept Technology, Inc., assumes no responsibility for any errors or omissions in the documentation. Critical evaluation of the documentation by the user is welcomed. Your comments assist us in preparation of future documentation. Please submit your comments to: [tech-pubs@adept.com](mailto:tech-pubs@adept.com).

Copyright © 2013-2014 by Adept Technology, Inc. All rights reserved.

Adept, the Adept logo, the Adept Technology logo, AdeptVision, AIM, Hexsight, Motivity, LaserPlans, Seekur, PatrolBot, and SILMA are registered trademarks of Adept Technology, Inc.

Brain on Board is a registered trademark of Adept Technology, Inc. in Germany.

Adept Enterprise Manager, Adept Enterprise Manager Lite, Adept Lynx, Adept SmartFleet EX, ARAM, MARC, MARCOS, MobileEyes, MobilePlanner, and SetNetGo are trademarks of Adept Technology, Inc.

Any trademarks from other companies used in this publication are the property of those respective companies.

MPEG Layer-3 audio coding technology licensed from Fraunhofer IIS and Thomson.

Copyright 2012 CEPSTRAL LLC <http://www.cepstral.com> This product may contain copyright material licensed from CEPSTRAL LLC, all right reserved.

Created in the United States of America

# Table of Contents

<b>Chapter 1: Introduction</b>	<b>9</b>
Definitions	9
1.1 Product Description	9
Body and Drive	10
What's Included - Basic Components	10
Optional Components and Attachments (partial list)	11
User-Supplied Components / System Requirements	11
Software Overview	11
1.2 Installation and Setup Overview	12
1.3 Dangers, Warnings, Cautions, and Notes	13
1.4 Safety Precautions	14
1.5 What to Do in an Emergency	14
1.6 Additional Safety Information	14
Manufacturer's Declaration of Conformity (MDOC)	14
Adept Robot Safety Guide	14
1.7 Manufacturer's Declaration	15
1.8 How Can I Get Help?	15
Related Manuals	16
Adept Document Library	16
Support	16
Including a Debuginfo File	17
<b>Chapter 2: Setup</b>	<b>19</b>
2.1 Transport and Storage	19
Platform	19
Battery Storage	19
2.2 Before Unpacking the Platform	19
2.3 Unpacking	20
Lifting the Platform	21
2.4 Repacking for Relocation	24
2.5 Operating Environment	24
2.6 Installing a Lynx System	24
Installing the Battery	24
Attaching the Payload and Options	26
Setting Up Wireless Ethernet	27
Installing the Docking Station	29

<b>Chapter 3: Getting Started</b> .....	<b>35</b>
3.1 Startup .....	35
Joystick .....	35
Follow Mode .....	36
3.2 Settings and Configuration .....	36
Maintenance Ethernet Connection .....	37
SetNetGo Configuration .....	37
Mapping .....	37
<b>Chapter 4: Payloads</b> .....	<b>39</b>
4.1 Considerations .....	39
Weight .....	39
Power Consumption .....	39
Payload Bay Access .....	40
Dimensions .....	41
Center of Gravity .....	41
4.2 Connections Between Platform and Payload .....	44
<b>Chapter 5: Connectivity</b> .....	<b>47</b>
5.1 Required Connections .....	47
5.2 Payload Bay Connections .....	47
Lynx Core Front, Upper .....	48
Lynx Core Rear, Upper .....	54
5.3 Internal Lynx Core Connections .....	61
Lynx Internal Data Pinouts .....	62
Lynx Internal Power Pinouts .....	64
<b>Chapter 6: Operation</b> .....	<b>67</b>
6.1 Operating Environment .....	67
6.2 Typical Operation .....	67
6.3 Power and Charging .....	68
Battery Indicators and Controls .....	68
Automated Docking Station .....	69
Manually Charging the Battery .....	71
6.4 Operator Panel .....	71
Screen .....	71
E-Stop .....	73
ON Button .....	73
OFF Button .....	73
Brake-release Button .....	74
Keyswitch .....	74
6.5 Other Controls and Indicators .....	74

Light Discs, Light Tower .....	74
Joystick .....	76
Maintenance Ethernet .....	77
Lynx Core Indicators .....	77
6.6 Sensors .....	78
Safety Scanning Laser .....	78
Sonar .....	78
Other Sensors .....	78
6.7 Startup .....	79
<b>Chapter 7: Options .....</b>	<b>81</b>
<b>Chapter 8: Maintenance .....</b>	<b>83</b>
8.1 Safety Aspects While Performing Maintenance .....	84
8.2 Periodic Maintenance Schedule .....	84
Cleaning .....	84
Tires .....	85
Axles .....	85
Lasers .....	85
Docking Station Contacts .....	85
8.3 Accessing the Payload Bay .....	85
8.4 Removing and Installing Covers .....	85
Cover Removal .....	86
Cover Installation .....	89
8.5 Replacing Periodic Parts .....	91
Battery .....	91
8.6 Replacing Non-Periodic Parts .....	94
Docking Station Roller and Bearing .....	94
Docking Station AC Power Fuse .....	95
Docking Station Internal Fuse .....	96
Rear Sonar Units .....	97
Front Sonar Units .....	97
Sonar Controllers .....	97
Light Discs .....	99
Operator Panel .....	99
Drive Assemblies .....	99
Front or Rear Casters .....	101
Safety Scanning Laser .....	103
Lynx Core .....	105
E-Stop and Safety Laser Commissioning .....	107
8.7 Spare Parts List .....	108
<b>Chapter 9: Technical Specifications .....</b>	<b>111</b>
9.1 Dimension Drawings .....	111

9.2 Platform Specifications .....112  
9.3 Docking Station Specifications .....114



# Chapter 1: Introduction

---

This manual covers the setup, operation, and user maintenance of the Adept Lynx™ platform.

Other than the basics, this manual does not cover configuration performed using the software that comes with the platform. That is covered in the [Adept Motivity® User's Guide](#).

## Definitions

**Platform:** The most basic part of the robot. It includes the chassis, drive assemblies, suspension, wheels, battery, safety scanning laser, sonar, an on-board Lynx core with a built-in gyroscope, software needed to navigate, connectors for interfacing with and powering the payload, and the robot covers.

**Payload:** Anything you attach to the Lynx platform. This could be as simple as a box for holding parts or documents that you want transported, or as complicated as a robotic arm that will be used to pick up parts to transport.

**AIV (Autonomous Indoor Vehicle):** The Lynx platform with a payload attached to it. This is your complete mobile robot, which will transport your products, parts, or data.

When referring to the initial setup, configuration, and connections, we will refer to the platform.

When talking about controlling or monitoring the full mobile robot, with a payload attached, we will refer to the AIV.

## 1.1 Product Description

The Adept Lynx platform is a general-purpose, indoor mobile robot platform, designed and sized to carry loads up to 60 kg (132 lb) while working around people. It is self-guided and self-charging, with an automated docking station. The platform's size and drive assembly are designed to work in any wheelchair-accessible environment.

The platform combines hardware and mobile-robotics software to provide an intelligent, mobile platform to support and transport your payload. The platform comes complete with the ability to know where it is within an indoor workspace, and to navigate safely and autonomously to any accessible destination within that workspace, continuously and without human intervention.

Its primary guidance uses a safety scanning laser to navigate, comparing the laser readings to a digital map stored on the platform. The laser is backed up by four front- and four rear-facing sonar units, a front sensing bumper, a gyroscope mounted on the internal Lynx core, and encoders and Hall sensors on each drive wheel.

For situations which are so dynamic that laser localization becomes difficult, Adept offers the Acuity Localization option, which localizes the platform using an upward-facing camera to recognize overhead lighting patterns. Refer to the Adept Lynx Platform Peripherals Guide. This would apply to areas where objects, such as pallets or carts, are moved so frequently that they can't be mapped, or where they block the laser's view of the mapped features.

For most applications, you will want to customize the Lynx platform with a payload, attached to the top of the platform, to hold, carry, or handle your parts, samples, or documents. Refer to Payloads on page 39 for general information on designing a payload.

The Adept Lynx platform provides a variety of interfaces and power connections to support your application-specific sensors and accessories, mounted on your payload. Refer to Connectivity on page 47, for information on the available connectors on the Lynx platform.

## Body and Drive

The Adept Lynx platform is relatively small, lightweight, and highly maneuverable. It has a strong aluminum chassis and solid construction that makes it very durable. It is insulated against water splashes and dust, with an IP rating of IP-44.

The platform is a two-wheel, differential-drive vehicle, with spring-loaded passive casters front and rear, and independent drive-wheel spring-suspension for balance. Its solid, foam-filled wheels are at the mid-line of the platform, so that the platform can turn in place.

## What's Included - Basic Components

- One fully-assembled Lynx platform

The platform includes a safety scanning laser, front bumper with four sonar discs, and four rear-facing sonar discs.
- One fully-charged battery

This is shipped separately from the platform, due to air shipping regulations.
- Lynx core, which includes an integrated computer, running Advanced Robotics Automation Management (ARAM™) and a microcontroller with MARCOS™ firmware. The core is housed inside the Lynx platform. It also runs the SetNetGo™ OS.

ARAM and MARCOS firmware and the SetNetGo OS are pre-loaded on the platform.

A gyroscope is mounted on the Lynx core, and each drive wheel has an encoder and a Hall sensor to complement the safety scanning laser.
- Operator Panel

This includes a screen, an E-Stop button, ON and OFF buttons, a brake-release button, and a keyswitch, which can be locked, and key removed, in either position. This will usually be mounted on the user-designed and -built payload.
- Automated docking station

Allows the platform to charge itself, without user intervention. This includes a wall-mount bracket and a floor plate, for a choice of installation methods. See Installing the Docking Station on page 29.

A manual charging cord is included, so you can charge the battery or a spare battery outside of the platform.
- Joystick

Used for manually controlling the platform, mostly when making a scan to be used for generating a map.
- User documentation

## Optional Components and Attachments (partial list)

- Adept Enterprise Manager™

This is the combination of the ARAMCentral software running on an Adept SmartFleet EX™ appliance, used for multi-AIV (fleet) coordination

The software requires either the Adept Enterprise Manager™ or Adept Enterprise Manager Lite™ license.

- Spare batteries
- Vertical-mount Object Detection Lasers

Option for payload development.

- Payload Sonar Kit

Includes eight sonar emitters/receivers and one sonar controller, which handles the eight sonar units.

- Cleanroom version

The platform is available in a cleanroom-suitable version.

- Call buttons

Either RF Mesh, WiFi, or wired Ethernet.

## User-Supplied Components / System Requirements

PC with Microsoft Windows®

- Ethernet (wireless preferred)
- 100 megabytes of available hard-disk storage

## Software Overview

A fair amount of software is involved in setting up and running an Adept Lynx platform.

The platform comes with the following software (listed from lowest- to highest-level):

### **MARCOS**

At the lowest level, a microcontroller running MARCOS firmware handles the details of mobility, including maintaining the platform's drive speed and heading, as well as acquiring sensor readings, such as from the encoders and gyroscope, and managing the platform's emergency stop systems, bumper, and joystick. The MARCOS firmware computes and reports the platform's odometry (X, Y, and heading) and a variety of other low-level operating conditions to ARAM.

### **SetNetGo**

The SetNetGo OS runs on the Lynx core. It is usually accessed through the SetNetGo interface in the MobilePlanner™ software. It can also be accessed through the maintenance Ethernet port or, when enabled, wirelessly over the network. It is used for the original wireless Ethernet configuration of the platform, and to perform systems diagnostics, such as retrieving log files. It is also used to update ARAM.

**NOTE:** It is also possible to connect directly to the SetNetGo OS on a platform through a web browser. The main intent of this is to allow your IT support to set up the network for you, without using MobilePlanner, which requires a license.

## **ARAM**

The Advanced Robotics Automation Management software (ARAM™) runs on the Lynx core. It operates ranging sensors like the safety scanning laser and sonar, and performs all the high-level, autonomous robotics functions, including obstacle avoidance, path planning, localization, navigation, and so on, culminating in motion commands to the MARCOS firmware. ARAM also controls the battery and light discs, and manages digital and analog I/O, which, along with platform power, provide for integration of application-specific sensors and effectors (user-supplied).

## **ARAMCentral**

ARAMCentral is the software that runs on the Adept SmartFleet EX appliance. This software and the appliance combined are referred to as the Enterprise Manager.

For a fleet, the ARAMCentral software manages:

- the map that all AIVs use
- the configuration that all AIVs use
- traffic control of the AIVs

This includes multi-robot avoidance, destination, standby, and dock control.

- queuing of jobs for the AIVs
- remote I/O, if you are using it

## **MobilePlanner (licensed)**

In order to have your AIV perform autonomous mobile activities, you need to make a map of its operating space, and configure its operating parameters. The MobilePlanner software is used to make this map and perform this configuration.

Refer to the separate [Adept Motivity® User's Guide](#) for details on how to map a working space and prepare the virtual elements, goals, routes, and tasks for your application.

The MobilePlanner software requires a license to run. You will need at least one license for MobilePlanner for each fleet of AIVs. Once you generate a map for an area, it can be shared between multiple AIVs in one fleet.

## **MobileEyes**

The MobileEyes software is used to monitor one or more AIVs' activities and have them perform mobile tasks in the mapped space. Refer to the [Adept Motivity® User's Guide](#) for details.

## **1.2 Installation and Setup Overview**

Most of the steps in setting up a Lynx platform are straightforward. The design and construction of the payload needs to be tailored to your application.

- Install the docking station. See [Installing the Docking Station](#) on page 29.
- Install the battery in the platform. See [Installing the Battery](#) on page 24.
- Set up the wireless Ethernet for the platform. See [Settings and Configuration](#) on page 36.
- Design, build, and install a payload for your application. See [Payloads](#) on page 39.  
This is the most involved task in getting your AIV working the way you want.
- Configure the AIV for your environment, so it can perform useful tasks.  
This includes generating the map that the AIV will use for its navigation. The configuration is covered in the [Adept Motivity® User's Guide](#).

### 1.3 Dangers, Warnings, Cautions, and Notes

There are five levels of special alert notation used in Adept manuals. In descending order of importance, they are:



**DANGER:** This indicates an imminently hazardous electrical situation which, if not avoided, will result in death or serious injury.



**DANGER:** This indicates an imminently hazardous situation which, if not avoided, will result in death or serious injury.



**WARNING:** This indicates a potentially hazardous electrical situation which, if not avoided, could result in serious injury or major damage to the equipment.



**WARNING:** This indicates a potentially hazardous situation which, if not avoided, could result in serious injury or major damage to the equipment.



**CAUTION:** This indicates a situation which, if not avoided, could result in minor injury or damage to the equipment.

**NOTE:** Notes provide supplementary information, emphasize a point or procedure, or give a tip for easier operation.

## 1.4 Safety Precautions

Read the installation and operation instructions, as well as the [Adept Robot Safety Guide](#), before using the equipment.

- Do not ride on the Lynx platform.
- Do not exceed the maximum weight limit.
- Limit operation to a 1:12 slope.
- Do not drop the platform, run it off a ledge, or otherwise operate it in an irresponsible manner.
- Do not get the platform wet. Do not expose the platform to rain or moisture.
- Do not use power extension cords with the docking station unless properly rated.
- Do not continue to run the platform after hair, yarn, string, or any other items have become wound around the platform's axles or wheels.
- Never access the interior of the platform with the charger attached. Immediately disconnect the battery after opening the battery compartment door.
- Do not use parts not authorized by Adept.
- Do not use any charger not supplied by Adept.

## 1.5 What to Do in an Emergency

Press the E-Stop button (a red push-button on a yellow background/field) and then follow the internal procedures of your company or organization for an emergency situation. If a fire occurs, use a type D extinguisher: foam, dry chemical, or CO<sub>2</sub>.

## 1.6 Additional Safety Information

Adept provides other sources for more safety information:

### Manufacturer's Declaration of Conformity (MDOC)

This lists all standards with which the Lynx platform complies. See Manufacturer's Declaration on page 15.

### Adept Robot Safety Guide

The [Adept Robot Safety Guide](#) provides detailed information on safety for Adept robots. It also gives resources for more information on relevant standards.

It ships with each robot, and is also available from the Adept Document Library. Refer to Adept Document Library on page 16.

## 1.7 Manufacturer's Declaration

The Manufacturer's Declaration of Incorporation and Conformity (MDOC) for Adept robot systems can be found on the Adept website, in the Download Center of the Support section.

<http://www.adept.com/support/downloads/file-search>

The Download Center requires that you be logged in for access. If you are not logged in, you will be redirected to the Adept website Login page, and then automatically returned to the Download Center when you have completed the login process.

1. From the Download Types drop-down list, select Manufacturer Declarations.
2. From the Product drop-down list, select Adept Mobile Robots.
3. Click Begin Search. The list of available documents is shown in the Search Results area, which opens at the bottom of the page. You may need to scroll down to see it.
4. Use the Description column to locate the document for your Adept robot, and then click the corresponding Download ID number to access the Download Details page.
5. On the Download Details page, click Download to open or save the file.

## 1.8 How Can I Get Help?

Refer to the How to Get Help Resource Guide (Adept P/N 00961-00700) for details on getting assistance with your Adept software and hardware. Additionally, you can access information sources on Adept's corporate website:

<http://www.adept.com>

For details on getting assistance with your Adept software or hardware, you can access the following information sources on the Adept corporate website:

- For contact information:  
<http://www.adept.com/contact/americas>
- For product support information:  
<http://www.adept.com/support/service-and-support/main>
- For user discussions, support, and programming examples:  
<http://www.adept.com/forum/>
- For further information about Adept Technology, Inc.:  
<http://www.adept.com>

## Related Manuals

This manual covers the installation, setup, operation, and maintenance of a Lynx platform. There are additional manuals that cover configuring the platform. See the following table. These manuals are available on the software media delivered with your system, and on the online Adept Document Library.

Table 1-1. Related Manuals

Manual Title	Description
<a href="#">Adept Robot Safety Guide</a>	Contains general safety information for all Adept robots.
<a href="#">Adept Motivity® User's Guide</a>	Covers MobileEyes and MobilePlanner software, the SetNetGo OS, and most of the configuration of a Lynx platform.
<a href="#">Adept SmartFleet EX Appliance User's Guide</a>	Covers the Adept SmartFleet EX Appliance and the Adept Enterprise Manager, for managing a fleet of Lynx AIVs.
<a href="#">Adept Lynx Platform Peripherals Guide</a>	Covers the Lynx Touchscreen, Call/Door boxes, and Acuity Localization for the Lynx.
<a href="#">How to Get Help Resource Guide</a>	Covers general information for getting information on Adept products. Gives WEEE information.

## Adept Document Library

The Adept Document Library (ADL) contains documentation for Adept products. You can access the ADL from the Adept website. Select **Support > Document Library** from the Adept home page. To go directly to the Adept Document Library, use the following URL:

[http://www.adept.com/Main/KE/DATA/adept\\_search.htm](http://www.adept.com/Main/KE/DATA/adept_search.htm)

To locate information on a specific topic, use the Document Library search engine on the ADL main page. To view a list of available product documentation, use the menu links located above the search field.

## Support

If, after reading this manual, you are having problems with your Adept Lynx platform, contact us at:

[support@adept.com](mailto:support@adept.com)

- In the body of your e-mail message, provide your platform's serial number and describe the problem you are having in as much detail as possible.
- Attach your debuginfo file to the email. Refer to the next section for details on retrieving your debuginfo file.

Tell us when and how we can best contact you. We will assume e-mail is the best format, unless otherwise notified. We will try to resolve the problem through communication. If the platform must be returned to the factory for repair, obtain a Repair Authorization Code and shipping details from us first.



## Including a Debuginfo File

If the Lynx platform has been set up on a wireless network, skip to SetNetGo Access on page 18.

### Network Setup

If the Lynx platform has not been set up on a wireless network, a local area network will have to be set up on a separate PC, and configured to talk to the Lynx platform over a TCP/IP port. The IP address should be set to: 1.2.3.5. The Subnet Mask should be 255.255.255.0.

#### (XP) Start > Control Panel > Network Connections

Right-click on the LAN Connection. Select Properties.

#### (Windows 7) Start > Control Panel > (Network and Internet >) Network and Sharing Center > Change adapter settings

Right-click on the LAN Connection, and click on Properties.

For both XP and Windows 7, from the Properties dialog, scroll to and double-click the Internet Protocol (TCP/IP or TCP/IPv4) option. In Internet Protocol Properties, click both 'Use the following...' radio buttons to enable them, and then type in the IP and netmask values.

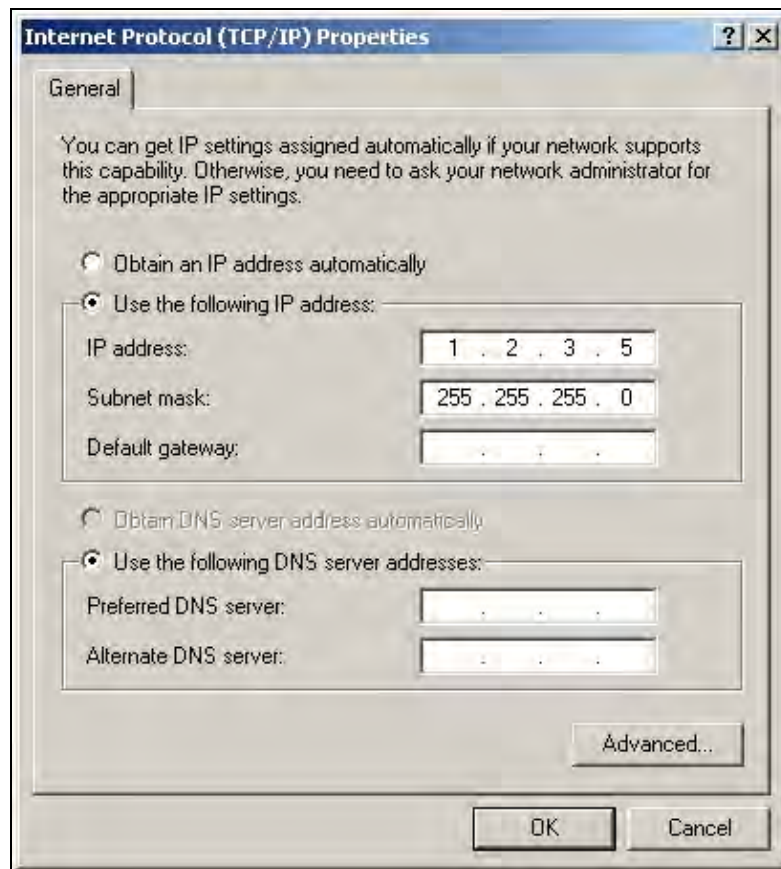

Connect the network port of your computer to the platform's maintenance port. See the figure Location of Parts on the Platform on page 83.

## SetNetGo Access

If the MobilePlanner software is available, use the SetNetGo interface within that software to access SetNetGo. Otherwise, open a web browser and enter the URL: <https://1.2.3.4>:

You will be requested to confirm security certificates.

Regardless of how you accessed SetNetGo, you should now have a window similar to the following:

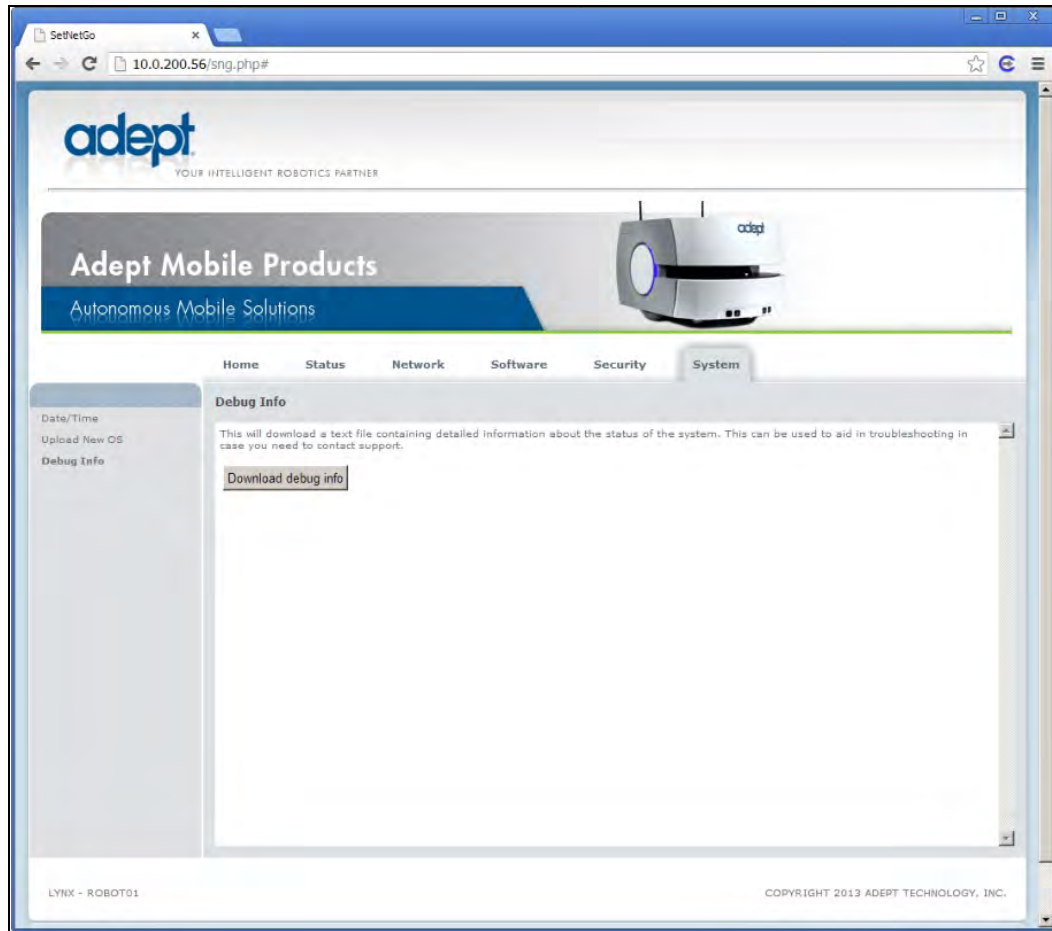

1. From the SetNetGo screen, select:

**System > Debug Info**

This will display the “Download debug info” button.

2. Click Download debug info.
3. Save the downloaded file, and attach it to your support request.

## Chapter 2: Setup

---

In general, setup is the physical and logical preparation of the platform, configuration of the wireless network, and the installation of the docking station. The physical preparation of the platform includes attaching your payload to the platform.

Setup includes generation of the map that the platform will use for navigation. This manual only provides an overview of that process, which is covered in detail in the [Adept Motivity® User's Guide](#).

### 2.1 Transport and Storage

#### Platform

The Adept Lynx platform must be shipped and stored in a temperature-controlled environment, from 5° to 70° C (41° to 158° F). The recommended humidity range is 5 to 95%, non-condensing. It should be shipped and stored in the Adept-supplied shipping container, which is designed to prevent damage from normal shock and vibration. You should protect the container from excessive shock and vibration.

Use a forklift, pallet jack, or similar device to transport and store the shipping crate.

The platform must always be stored and shipped in an upright position in a clean, dry area that is free from condensation. Do not lay the crate on its side or any other non-upright position. This could damage the platform.

The crate with pallet for the platform measures 1219 x 711 x 762 mm (48 x 28 x 30 in.), and weighs 95 kg (210 lb).

#### Battery Storage

**NOTE:** If you purchased spare batteries, this section applies to them, also.

The battery is shipped in a separate container, not inside the Lynx platform. Its crate with pallet measures 457 x 279 x 406 mm (18 x 11 x 16 in.), and weighs 27 kg (60 lb).

If the battery needs to be stored, the manufacturer recommends 5° to 70° C (41° to 158° F).

The battery should start storage fully-charged. If the battery will be stored for an extended period, it should be recharged periodically to avoid total discharge, which will damage the battery. Recharging a battery every six months is sufficient to keep it charged enough to avoid damage.

### 2.2 Before Unpacking the Platform

Carefully inspect all shipping containers for evidence of damage during transit. If any damage is indicated, request that the carrier's agent be present at the time the container is unpacked.

## 2.3 Unpacking

Before signing the carrier's delivery sheet, compare the actual items received (not just the packing slip) with your equipment purchase order. Verify that all items are present and that the shipment is correct and free of visible damage.

- If the items received do not match the packing slip, or are damaged, do not sign the receipt.
- If the items received do not match your order, please contact Adept immediately.

Retain the crates and packaging materials. These items may be necessary to settle claims or, at a later date, to relocate the equipment.

The Adept Lynx platform comes packed in a wooden crate, lined with foam. It is mounted on a pallet, with a wooden cover. See the following two figures.

The docking station, joystick, and platform are shipped in the same crate. The joystick is in the smaller compartment on the near side in the previous figure.

The battery is shipped in a separate crate.

1. Remove the lag screws that attach the crate cover to the pallet.
2. Lift off the crate cover to reveal the crate, pallet, and contents.
3. Remove the two wing nuts and washers holding the back panel of the crate to the crate. Retain the two wing nuts and washers for reassembly.
4. Remove the back panel. Retain the back panel.
5. Remove the docking station.
6. Remove the tie-downs (not shown here) that hold the platform in place.

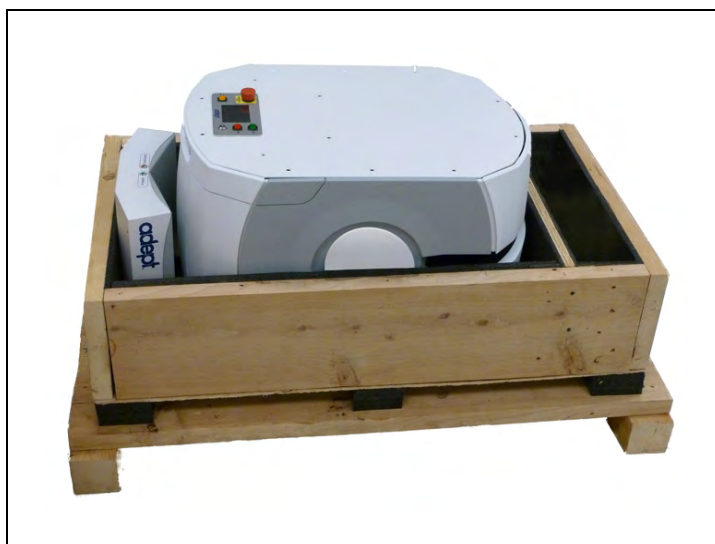

Figure 2-1. Side View of Docking Station and Platform in Crate



Figure 2-2. Adept Lynx Platform in Shipping Crate, on Pallet, with Crate Cover

### Lifting the Platform



**CAUTION:** You can damage the platform if you lift it incorrectly.

- Use two people to lift the platform out of its crate.
- Lift **ONLY** at the points shown.

### Front Lifting Points

Lift on each side of the laser, under the upper side of the laser slot.

Do not lift at the center, where the laser is located. There is no frame support there.

Do not lift anywhere else! Refer to the following figure:

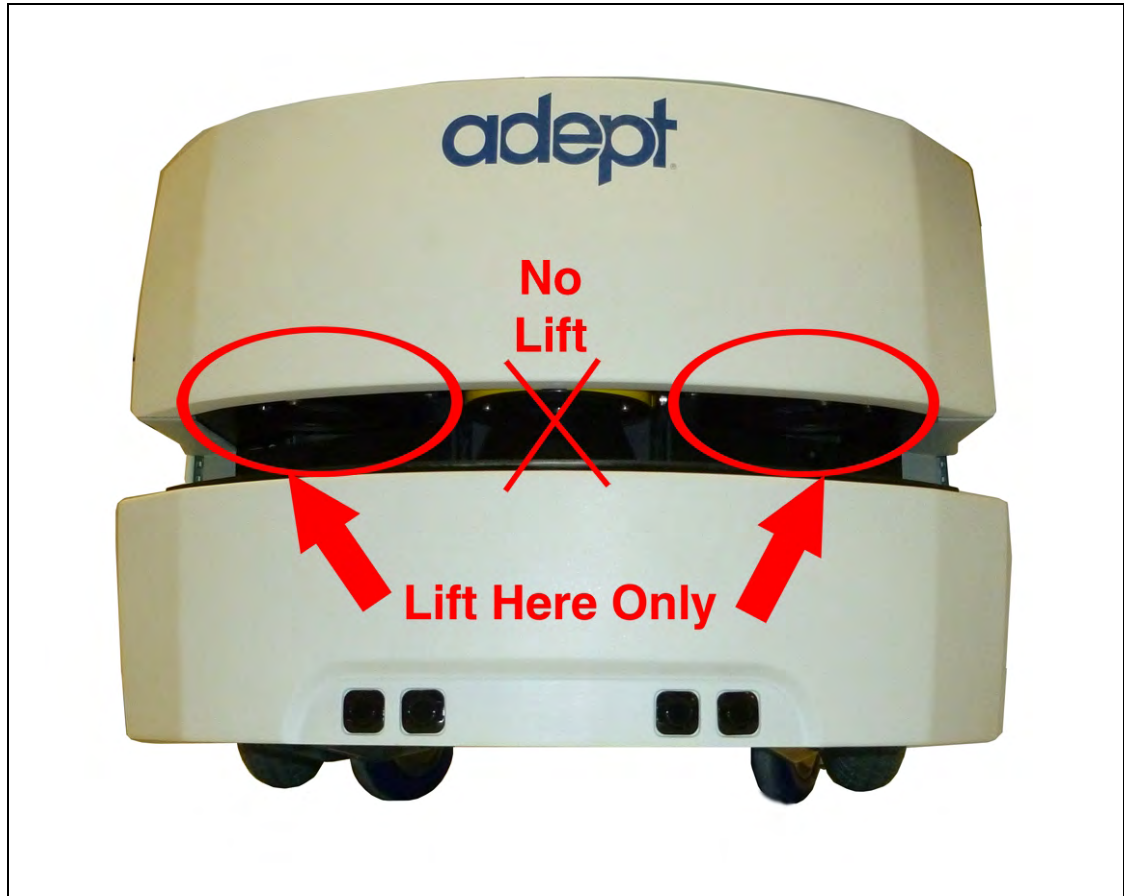

Figure 2-3. Upper Side of Laser Slot, at Sides, NOT at Center

### Rear Lifting Points

Lift near the center of the platform, where the cover has a raised section.

Do not lift anywhere else.

Refer to the following figure:



Figure 2-4. Bottom of Inner Rear Cover. Lift from the Frame, not the Cover.

The following split photo shows a platform being lifted out of its crate:



1. Lift the platform out of the crate.
2. Re-install the back panel, using the two wing nuts and washers.

## 2.4 Repacking for Relocation

If the platform or other equipment needs to be relocated, reverse the steps in the installation procedures in this chapter. Reuse the original packing crate and materials and follow all safety notes used for installation. Improper packaging for shipment will void your warranty.

The platform must always be shipped in an upright orientation.

## 2.5 Operating Environment

The Adept Lynx platform is designed to operate in an environment that is wheelchair accessible. Care must be taken to avoid:

- glass doors and walls
- pits without railings or low bumpers
- floors with access panels removed
- loose cables, hoses, etc.
- large, highly-reflective objects

Floors must provide good traction, typical of good walking conditions.

- Slope up to 1:12
- Step traversal up to 15 mm (0.6 in.)
- Gap traversal up to 15 mm (0.6 in.)
- Temperature 5° to 40° C (41° to 104° F)
- Humidity 5 to 95%, non-condensing

The Adept Lynx platform is not intended for use in hazardous environments (explosive gas, water, dust, oil mist). It has an IP rating of IP-44.

## 2.6 Installing a Lynx System

### Installing the Battery

Your Adept Lynx platform comes fully-assembled, battery fully-charged.

**NOTE:** Air shipping regulations require that the platform be shipped without the battery installed.

Refer to Removing and Installing Covers in the Maintenance section for cover removal and installation.

1. Remove the inner rear platform cover.
2. Unlatch and open the battery compartment door, at the back of the platform.

The battery compartment door is capable of being locked. You may need to unlock it.





Figure 2-5. Battery Compartment Door (keys are zip-tied for shipping)

3. Lift and slide the new battery into the platform body.

The battery weighs 20 kg (44 lbs).

There are recesses at the front and the back of the battery, to aid in lifting it.



Figure 2-6. Battery Recesses, for Gripping

The battery is designed to be lifted and replaced by one person, using one hand in each of the grips, as shown in the following figure.



Figure 2-7. Lifting the Battery

The connectors for power and data go toward the rear of the platform.

4. Attach the battery power and data cables to the connectors at the rear of the battery.
5. Close the battery compartment door to secure the battery in place.

The battery compartment is designed to hold the battery tightly, so that it will not move within the compartment, once the door is closed.

6. Reinstall the inner rear platform cover.

### Attaching the Payload and Options

You may need to attach any accessories that were shipped separately or detached for safety. You will also have to attach your payload. See Payloads on page 39.

**NOTE:** An E-Stop jumper or a user-supplied E-Stop button needs to be attached to the E-STOP port (User Interface) for the platform to function. The jumper is provided as part number 12730-000L. An E-Stop button would be user-supplied.

See the following figure.

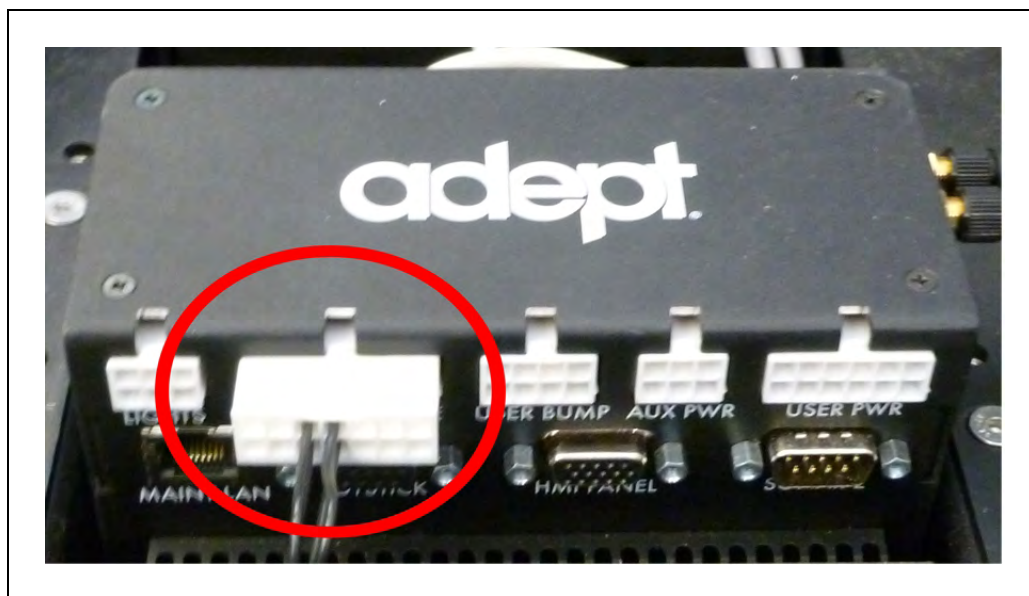

Figure 2-8. E-Stop Jumper on Lynx Core

## Setting Up Wireless Ethernet

**NOTE:** The Adept Lynx AIV is capable of working without wireless Ethernet. If there are no other AIVs that it needs to know about (and to avoid), you can have an installation in which the AIV simply uses its map, knows its patrol route, and performs without human intervention.

For example, you could set up a AIV to make stops, and wait for a specified period of time, and then continue on its patrol.

**NOTE:** For all of the following settings, work with your IT group to verify the correct IP, radio, and security settings.

The following applies to the wireless Ethernet supported by the Adept Lynx platform.

Access the SetNetGo OS through the MobilePlanner software:

**MobilePlanner > SetNetGo > Networking**

**NOTE:** It is also possible to connect directly to the SetNetGo OS on a platform through a web browser. The main intent of this is to allow your IT support to set up the network for you, without using MobilePlanner, which requires a license dongle.

### ***IP Address, Netmask, Gateway, DNS1***

Choose Static (DHCP is not recommended), and fill in the IP address, netmask, gateway, and DNS1, as supplied by your network administrator.

**NOTE:** The following settings have to be provided by your IT department.

### **Radio Settings**

- SSID (e.g. AGV)  
Fill in the appropriate wireless SSID for your wireless network.  
The SSID is case sensitive.
- Mode  
Managed/STA, Ad-Hoc, or Master/AP
- Radio Mode  
Auto, 802.11a, 802.11b, 802.11g
- Channel Set
- Wireless Watchdog IP Address
- Wireless Watchdog Max Count  
0 disables this.

### **Security Settings**

Encryption:

- Disabled
- WEP 64-bit
- WEP 128-bit
- TKIP/RC4
- CCMP/AES
- TKIP/CCMP/AES

Authentication:

- OPEN
- WPA-PSK
- WPA2-PSK

WEP

- WEP Key Number (Key 1 - Key 4)
- WEP Keys

WPA/WPA2-PSK

- PSK
- PSK-Type (Passphrase or Raw Hex)

Click Apply for your changes to take effect.

### Wireless Coverage

The Adept Lynx AIV must have wireless coverage for multi-AIV installations, or in areas where you wish to send new commands to or receive status updates from the AIV.

Ensure that, in such cases, you have adequate wireless coverage. Because of the variation possible in different environments, Adept doesn't specify what components or techniques should be used to obtain this coverage.

Adept suggests that you conduct a comprehensive site survey to ensure adequate wireless coverage. You can test the coverage of your wireless setup by trying to ping it from various locations.

### Bandwidth Considerations

The typical bandwidth in a fleet will average about 50 Kbps/AIV. This would increase if the AIV is connected to the Enterprise Manager, and is actively viewed by MobileEyes. This number can increase or decrease depending on the types of commands and debugging tools that are enabled in MobileEyes. In any case, the bandwidth is not likely to exceed 500 Kbps per AIV (0.5 Mbps).

0.5 Mbps per AIV would easily fit within the capabilities of access points ( $\geq 54$  Mbps). If you have multiple access points, this number becomes even less of a concern.

Also, other factors will affect the bandwidth requirements, such as if the AIV supports a camera on top and streams the video through the AIV's WiFi interface. Based on such possibilities, the bandwidth usage will vary by application.

### Installing the Docking Station

The automated docking station can be used for either manual or automated charging of your platform's battery.

The docking station sits on the floor. It can be attached to a wall with the wall bracket, attached directly to the floor with screws through its base, or can sit stand-alone on the floor with the floor plate, all of which will keep the docking station from moving when the platform docks. Both the wall bracket and floor plate are included with each docking station.



**CAUTION:** It is very important that the docking station be mounted with one of these methods, or the platform will simply move the docking station when it tries to dock, rather than docking successfully.

For all mounting methods:

- Locate the docking station near an AC outlet with 1 - 2 meters (3.25 - 6.5 ft) of clear space in front to ease the platform's maneuvers, especially automated ones, onto the docking station.
- The top of the docking station foot is spring-loaded, and lifts off of the bottom of the foot slightly to accommodate variations in the floor surface. The weight of the Lynx platform will push the top of the foot down.

**Requirements**

- 100 to 240 VAC, 50 to 60 Hz, 8 A  
The station's power converter automatically detects the source voltage.
- Ambient operating temperature: 5° to 40° C (41° to 104° F)
- 5 to 95% humidity, non-condensing

**Wall Bracket Mount**

1. Attach the docking station mounting bracket to a wall, with the bottom edge of the bracket  $98 \pm 20$  mm ( $3.8 \pm 0.8$  in.) above the floor, using user-supplied anchors and screws. There is leeway, so you can adjust the height a little bit.

Refer to the following figure:

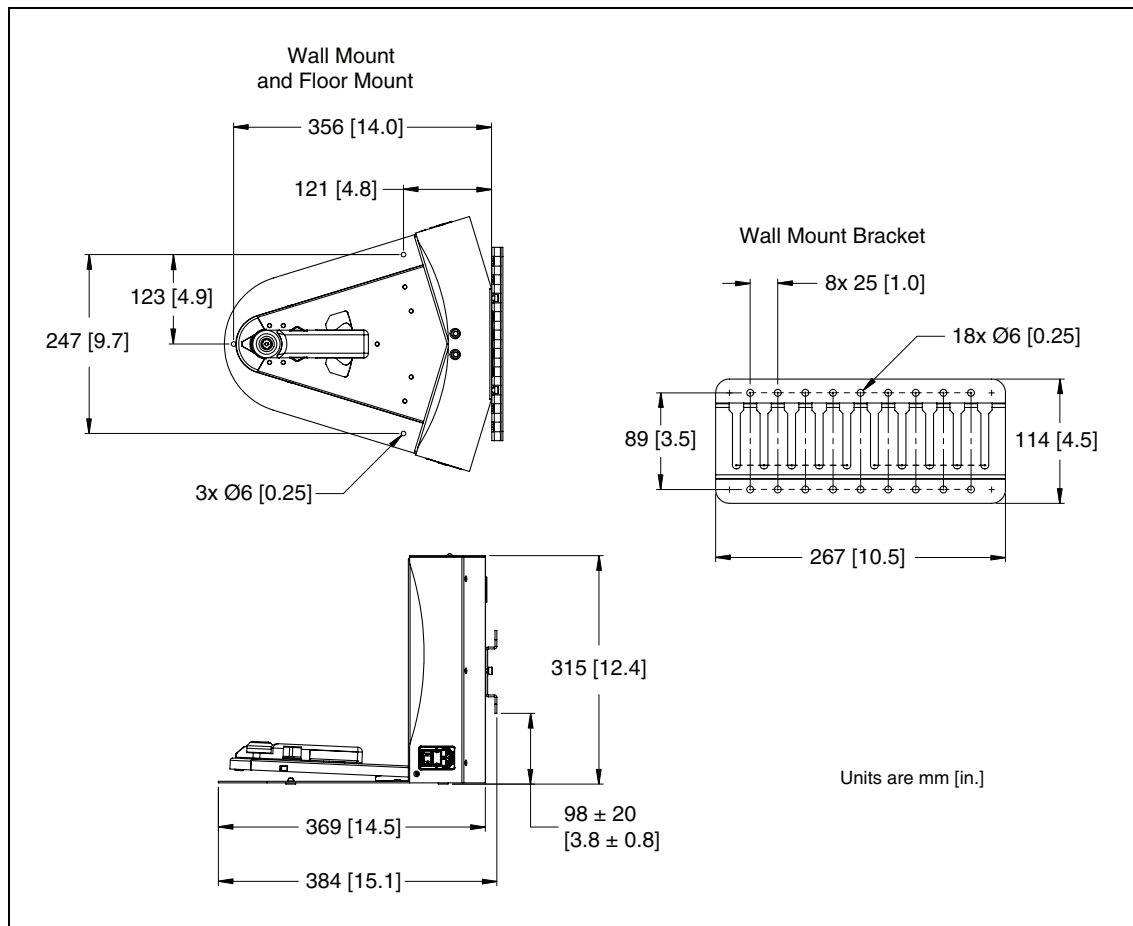

Figure 2-9. Docking Station, Wall Mount

2. Screw the two shoulder bolts, each with a washer, into the rear of the docking station. The shoulder bolts are M5 x 4, stainless steel. Their locations are shown in the following figure. Tighten to 9 N-m (80 in-lb).



Figure 2-10. Rear View of Docking Station with Wall Bracket

3. Lower the docking station down, so the two bolts on the back of the docking station slide into the bracket, to secure the docking station to the wall.

#### **Floor-mount, without Floor Plate**

Screw the base of the docking station directly to the floor, using three user-supplied screws. For dimensions of the available holes in the base, refer to Figure 2-9. Adept recommends M5 self-tapping or M4 sheet rock screws for this.

#### **Floor-mount, with Floor Plate**

This mounting method uses the floor plate. The floor plate is not shipped attached to the docking station, so you must attach it for this type of mount. It will be in the crate with the platform, right behind the docking station.

### Attaching the Floor Plate

Refer to the following figures.

1. Tip the docking station onto its back, so you can access the underside.
2. Remove the two lowest screws (M4 x 12 flat-head), if present.

In the following figure, these screws are circled. The location of the third screw hole is also circled.

3. Attach the floor plate to the base of the docking station with three M4 x 12 flat-head stainless steel screws.

The floor plate comes with three screws, so you will have two spares.

The docking station and floor plate do not need to be attached to the floor, as the weight of the AIV on the floor plate will keep the docking station from moving.



Figure 2-11. Underside of Docking Station Foot, Showing Screw Locations



**NOTE:** These are the three locations for the M4 x 12 flat-head screws. Two are already in place, and need to be removed before attaching the plate.



Figure 2-12. Docking Station, Mounted on Floor Plate

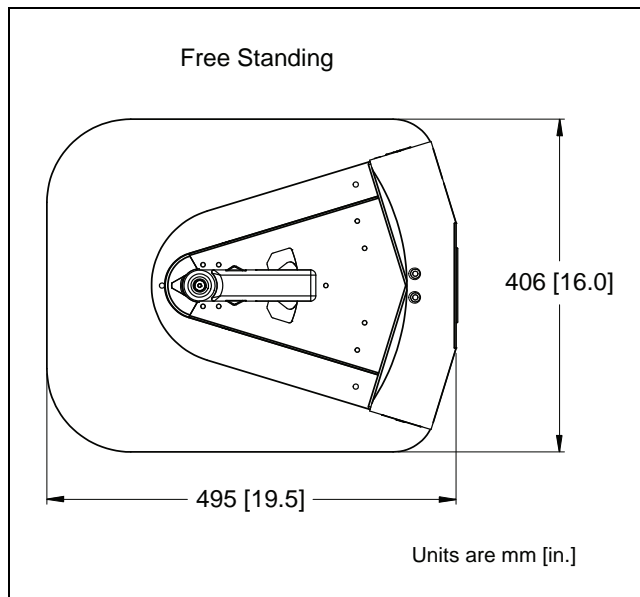

Figure 2-13. Docking Station Floor Plate Dimensions

### **All mounting methods**

Install the power cord and turn the power switch to ON. The power switch is next to the power plug. The blue power LED indicator should light.

### **Docking Station Contact Adjustment**

The contacts on the docking station have five height settings. The station is shipped with the height in the middle setting, which should be correct in most cases. The height can be changed by tilting the station enough to see the bottom of the base, making the adjustment accessible.

**NOTE:** Squeeze and keep the platform foot against the bottom of the foot to make this adjustment easier.

Adjust the height of the contacts by using the pull-knob on the bottom of the dock. The height changes by 4 mm (0.15 in.) for each notch.

The height of the contacts should be set so that the roller is high enough to stay in contact with the platform as it is docking, but low enough so that the bi-level of the roller guides the paddle under the platform.

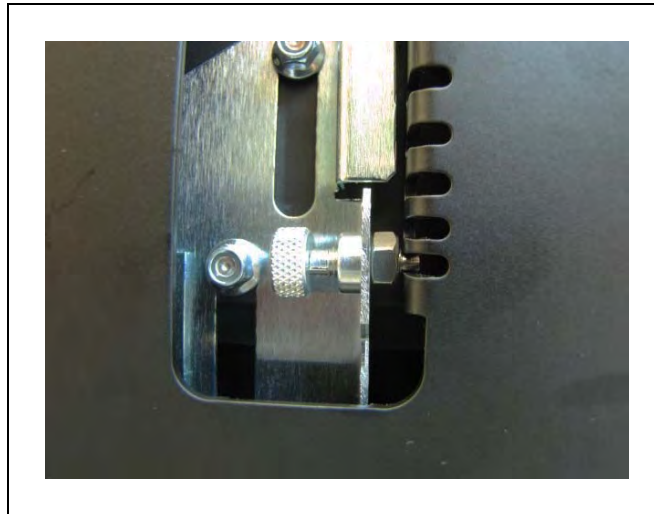

*Figure 2-14. Docking Station Contact Adjusting Pull-Knob*

## Chapter 3: Getting Started

---

The Adept Lynx platform comes with firmware and onboard software installed.

The configuration of parameters is performed with the MobilePlanner software, covered in the [Adept Motivity® User's Guide](#).

Other setup, mostly for communication, is handled by the SetNetGo OS, which is accessed through the MobilePlanner software. It can also be accessed through a direct connection, so your IT support can set up your wireless without needing the MobilePlanner dongle.

The Adept Lynx platform navigates using a map, generated with the MobilePlanner software. The operation of this software, as well as the downloading of the resultant map to the platform, is covered in the [Adept Motivity® User's Guide](#).

**NOTE:** The map must be generated and downloaded to the platform before you can perform the steps covered in the Operation chapter of this manual.

The Adept Lynx platform is autonomous, but can be monitored and manually controlled through the MobilePlanner or MobileEyes software. These are covered in the [Adept Motivity® User's Guide](#).

This chapter describes how to quickly start up, configure, and operate your new Adept Lynx platform. For mapping and integration details, refer to the [Adept Motivity® User's Guide](#).

### 3.1 Startup

Press and hold the power ON button for half a second, then release. It takes about a minute for all the systems to start up and make their various interconnections. If the platform doesn't start up, try power OFF, check your connections, and then power ON.

Startup is complete when the light discs stop indicating boot (two blue light segments, moving in opposite directions from 6 o'clock to 12 o'clock and back).

Out-of-the-box, the platform does not have a working map, nor are its wired or wireless network settings likely to match your network. Consequently, it will not do anything autonomously, but you can drive it with the joystick or have it follow you around, in Follow Mode. Adept recommends that you drive it to and position it onto its automated docking station in preparation for the next steps. (Installation of the automated docking station was covered in the previous chapter.)

#### Joystick

The joystick lets you quickly move the platform to its destination. This can be used to drive it from the shipping dock to an automated docking station.

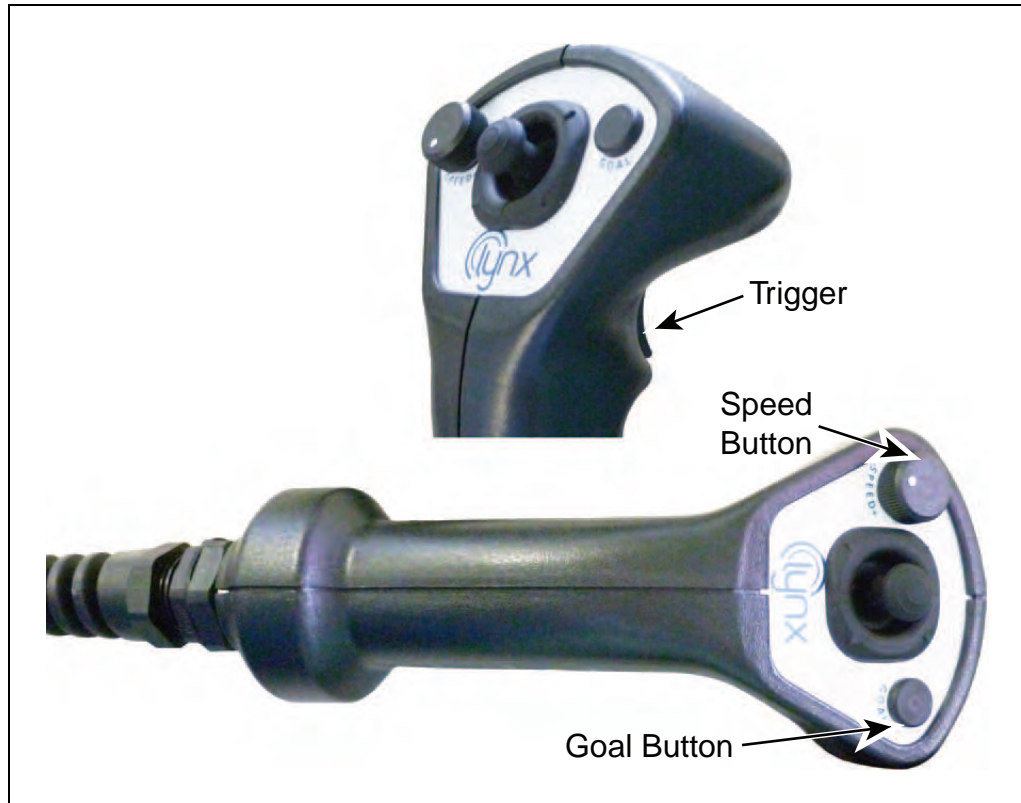

Figure 3-1. Joystick

The joystick plugs into the left side of the Lynx platform, under the small access panel at the upper right corner of the platform. (The Maintenance Ethernet port is also there.) The access panel is held in place with a push-push latch, and retained by a lanyard. See Figure 8-1.



**WARNING:** The Adept Lynx Platform Safety Scanning Laser is not tied into the E-Stop chain when driven using the joystick. The platform will still avoid obstacles detected by the Safety Scanning Laser. The sonar, on the other hand, are disabled entirely when driving with the joystick.

### Follow Mode

Connect the joystick, start up normally, then press the joystick GOAL button. Step in front of the platform and it will now follow you wherever you go. Actually, it follows your legs or the legs of anyone else who may step in front and capture its attention. This is useful if you need to transport it to a different location.

Driving with the joystick, activation of an E-Stop, or any other mobility interaction, such as through MobileEyes, stops Follow Mode.

## 3.2 Settings and Configuration

Preparing your Adept Lynx platform for autonomous mobile operation is very easy and takes just a few moments. You attach a PC to the platform's maintenance Ethernet port, and connect

with the SetNetGo OS through the MobilePlanner SetNetGo interface. If you do not have wireless yet, you can connect MobileEyes and MobilePlanner through the wired Ethernet port (Maintenance LAN) and set up the wireless network later.

## Maintenance Ethernet Connection

Attach a pass-through or cross-over CAT5 (or better) Ethernet cable between the PC and the Maintenance Ethernet port of the Adept Lynx platform. The Lynx Ethernet is Auto-MDIX, and will detect the type of cable you are using. Set your computer's IP address to 1.2.3.x, where x is any number from 1 through 254, except 4. Manually set the net mask to 255.255.255.0. No special DNS or gateway settings are needed.

The Maintenance Ethernet plugs into the left side of the Lynx platform, under the small access panel at the upper right corner of the platform. (The joystick port is also there.) The access panel is held in place with a push-push latch, and retained by a lanyard. See Figure 8-1.

The platform's Maintenance Ethernet port is always enabled, and permanently set to IP address 1.2.3.4, with a netmask of 255.255.255.0, for direct, wired access to the onboard systems.

Start the Network Connections:Local Area Connection dialog for the ETH 0 Ethernet port:

(Windows) **Start > Settings > Network Connections > Local Area Connection**

Select Properties, and, from its dialog, scroll to and double-click the Internet Protocol (TCP/IP) option. In the Internet Protocol (TCP/IP) Properties dialog, click both 'Use the following...' associated radio buttons to enable them, and then type in the IP and netmask values.

## SetNetGo Configuration

The SetNetGo OS is used to configure the Adept Lynx platform wireless Ethernet, among other things. Refer to the [Adept Motivity® User's Guide](#) for details.

## Mapping

In order to have your Adept Lynx platform perform autonomous mobile activities, you need to make a map of its operating space. Use the MobilePlanner application to make maps. Refer to the [Adept Motivity® User's Guide](#).

The tasks involved are:

- Make a floor plan scan while driving the platform with the joystick.
- Load that floor plan scan into MobilePlanner, on your PC, to make and edit the map.
- Transfer the working map back to the platform and share it with any other Lynx platforms in that workspace, to perform autonomous mobile actions.
- Save map collections and deploy your platform in any of your working spaces by selecting the appropriate map file.

**NOTE:** It is a good idea to have the automated docking station installed prior to creating the map scan. Its distinctive diagonal face will be useful in locating and setting it up in the map.



## Chapter 4: Payloads

---

Everything that you attach to the Lynx platform is referred to as the payload.

In some custom cases, Adept designs and builds the payload. In most cases, you will need to design a payload that suits your application. This chapter discusses considerations to be aware of when you design a payload for your Lynx platform.

The Lynx platform provides the mobility and navigation you will need, as well as power and I/O connections between the platform and your payload, so the two can work effectively together.

### 4.1 Considerations

The main factors to consider in designing a payload are the size, weight, and center of gravity of the payload, and power requirements. Adding weight to the Lynx platform tends to have less effect on run-time than adding electrical power requirements. Additional weight will have more effect on carpet than on hard surfaces.

#### Weight

Increased payload weight will decrease your AIV's run-time. This will be most noticeable if you are driving the AIV up an incline. On level ground, a certain amount of extra weight will not shorten the AIV's run-time very much. When adding a payload with substantial weight, the center of gravity of the entire AIV needs to be considered. This is particularly important if you intend to equip the Lynx platform with a robot arm, which would be lifting items off-center from the Lynx platform.

A heavy payload, with most of its weight concentrated just above the Lynx platform, will be much more stable than the same weight payload in which the weight is either off-center or high above the top of the platform.

**NOTE:** The weight of your payload added to the weight of the parts it is carrying must not exceed 60 kg (132 lb).

#### Power Consumption

Using devices on your payload that consume significant power will noticeably shorten the run-time of the AIV. You should try to minimize such power consumption whenever possible.

Examples of power-consuming payloads would be one with a robot arm attached, or any motorized fixture as part of the payload. The standard Operator screen and light discs consume some power, but are not significant compared to the rest of the platform.

The battery is rated at 1500 W\*hr (1.5 kWh). Unloaded, the platform uses from 80 - 107 W. With a full load, this increases to 94 - 125 W. (The range for each reflects the speed at which the platform is driven.) You can use the wattage of any accessories you add to your payload, added to these typical values, to calculate the expected run-time per charge.

**NOTE:** In the following table, 50% is 900 mm/sec., 100% is 1800 mm/sec.

Table 4-1. Typical Watts Drawn

	% Speed	
kg	50	100
0	80	107
60	94	125

To calculate your estimated run-time:

1. Find the closest match to your payload weight and average driving speed, as a percentage of full speed.

This will be a value in Watts.

2. Add the power used by all electrical devices on your payload, in Watts.

It is unlikely that any electrical device on your payload will operate continuously, so you need to figure out what average percent of the time it will operate, and multiply that by the Watts of the drain to get an average drain factor.

3. Divide 1500 W\*hr by that value, in Watts.

This will yield your estimated run-time, in hours.

### Example Calculation

If your payload weighs 60 kg, and you expect to run at an average of 50% full speed, you would use the value of 94 from the table.

If your payload includes a device that draws 150 watts half of the time, add 75 (150\*50%) to 94, to get 169 Watts, total.

Dividing 1500 W\*hr by 169 Watts yields:

$$1500 \text{ W*hr} / 169 \text{ W} = 8.87 \text{ hr of estimated run-time.}$$

### Payload Bay Access

The area between the Lynx platform and your payload is the payload bay. You will occasionally need to access the Lynx platform and the connectors in the payload bay. This is where you can access all of the platform power and I/O connectors. It's a good idea to provide for access to this when designing your payload.

If the payload is small and light enough, it can just be lifted off of the platform to access the connectors in the payload bay. Care should always be taken not to damage any wiring between your payload and the platform.

A larger, heavier payload may need some form of hinge, so that the payload can be tilted out of the way while you access the payload bay. Consideration should be given to harness length and position so that this can be accomplished without disconnecting or damaging any connectors or harnesses.



## Dimensions

You must keep your payload no wider and no longer than the Lynx platform. The most common payload is a vertical extension of the platform, adding whatever features are needed by your application above the platform itself.

Take care to keep all of the payload higher than the top of the Lynx platform. If any of the platform's sensors get blocked, it won't be able to function normally. This is critical in the case of the safety scanning laser.

If you purchased the optional vertical-mount lasers for your payload, you need to make sure that the payload will not interfere with the view of those lasers. Typically, the vertical lasers are mounted on the sides of the payload, so that they protrude enough to miss the payload itself with the laser beam. Some customers have found it prudent to build a protective guard over the vertical lasers, to protect the lasers from impact. Ensure that any such guard does not block the laser beam.

The height of your payload will affect the center of gravity, covered in the next section.

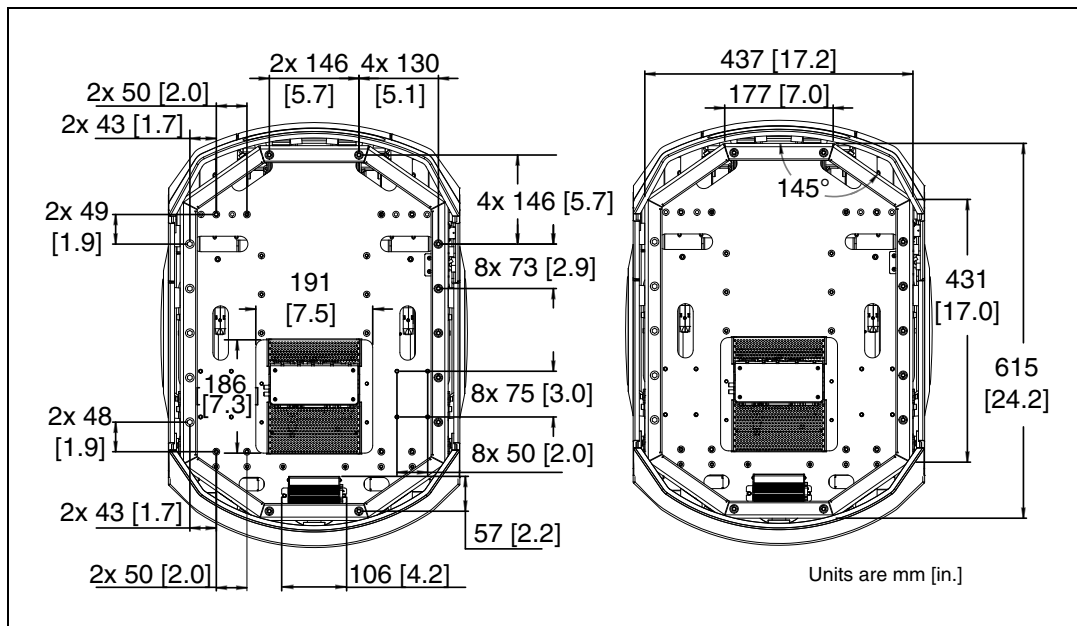

Figure 4-1. Platform Deck Dimensions, for Attaching Payload

## Center of Gravity

As much as possible, you should keep the payload center of gravity centered on the Lynx platform, and as low (close to the platform top) as possible. This will give you the best stability, particularly when crossing thresholds or irregularities in the floor.

The following figure shows the center of gravity of the platform, without payload.

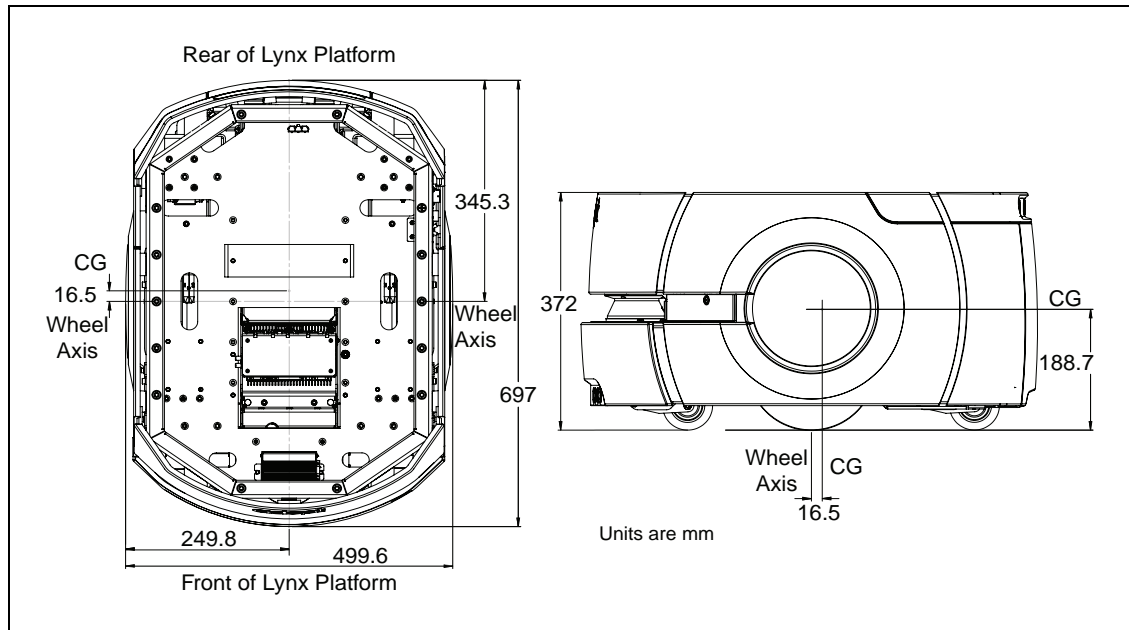

Figure 4-2. Center of Gravity of Platform

The three following figures show the calculations of safe placements for the center of gravity for payloads with the weights listed. The center of gravity, in each instance, needs to be within the area shown. All units are mm.

**NOTE:** These figures show the limits of where the payload center of gravity can be placed. You should try to keep your CG as close to the center of these figures as possible.

In the following three figures, light blue represents the payload, while dark (Adept) blue represents the Adept Lynx Platform.

**10 kg**

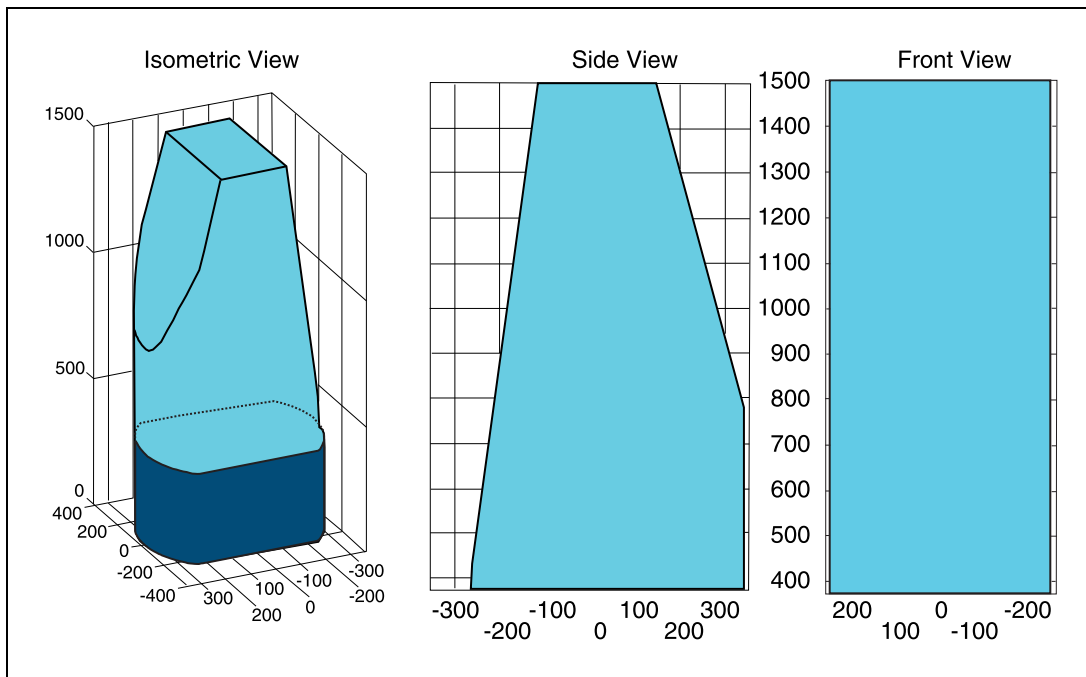

Figure 4-3. Center of Gravity Graphs, 10 kg

**30 kg**

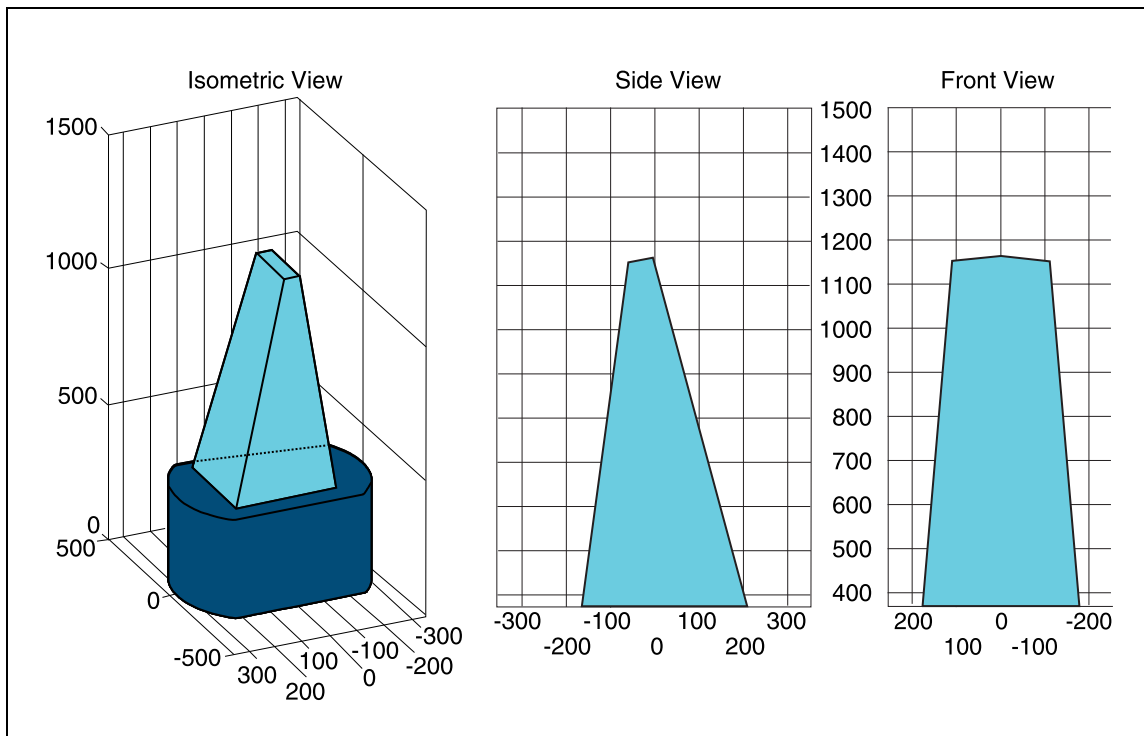

Figure 4-4. Center of Gravity Graphs, 30 kg

**60 kg**

Figure 4-5. Center of Gravity Graphs, 60 kg

## 4.2 Connections Between Platform and Payload

The Lynx platform provides a variety of I/O and power connections, which you can use to make your AIV more effective.

The Operator screen, E-Stop, Brake-release, ON, and OFF can be "moved" using a single connector (the HMI Panel connector). This allows you to put many of the more common operator controls somewhere on your payload with just one cable.

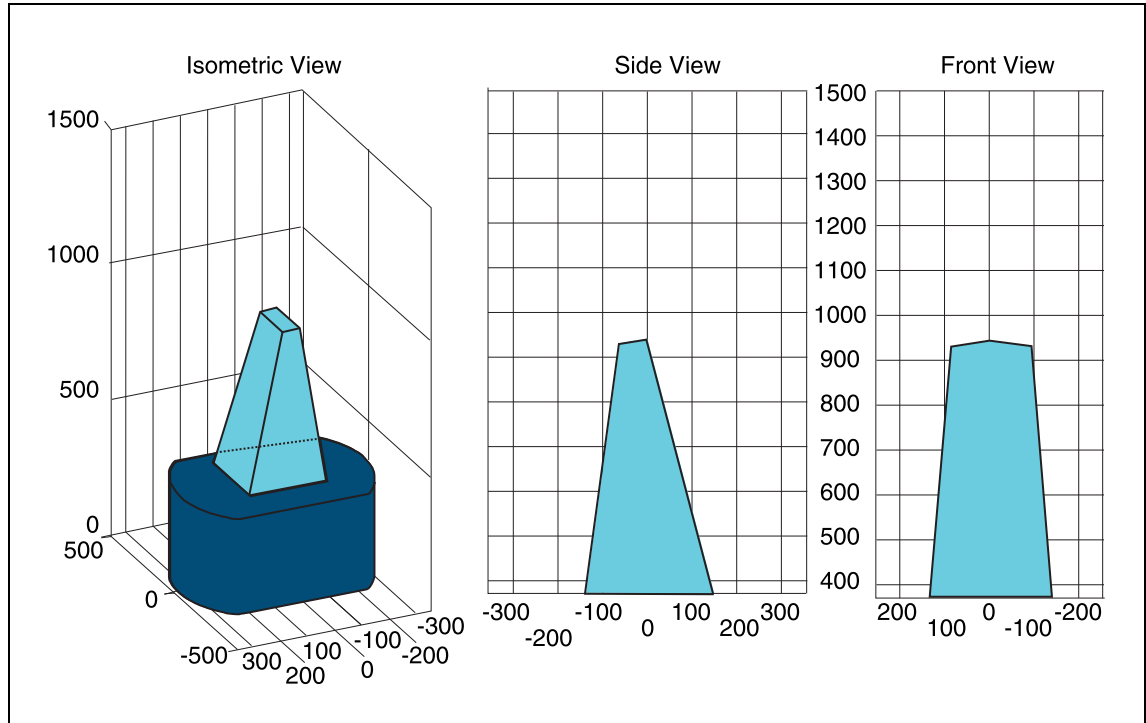
The cutout needed for mounting the Operator interface is shown in the following figure:

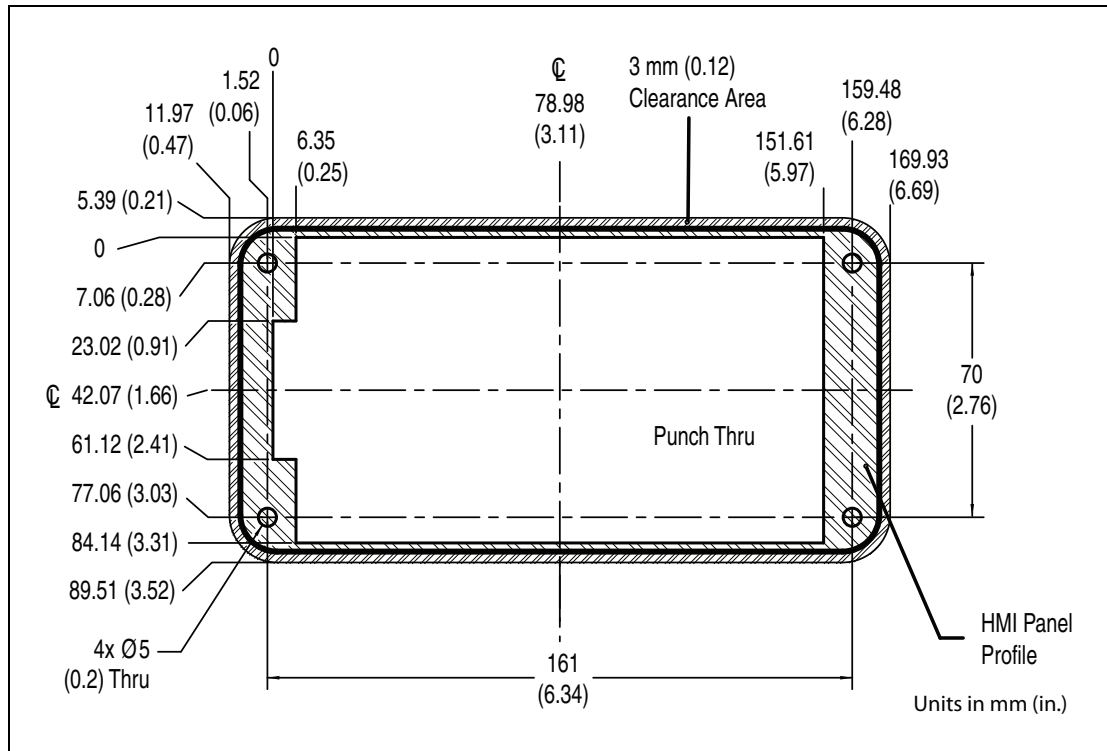

Figure 4-6. Operator Interface Cutout Dimensions

Many other options are available. Details and specifications of the connections available are covered in Connectivity on page 47.



# Chapter 5: Connectivity

---

Most of the connections that are available to the user are in the payload bay, which is the space between the platform and any payload placed on top of it. These include I/O and power connections. Some are required; others are available if needed. The two exceptions are the Joystick port, and the Maintenance Ethernet port, which are located under a small access panel on the left side of the Lynx platform, in the upper-right corner. Both of these connectors have a second, equivalent connector inside the payload bay. See Figure 8-1.

## 5.1 Required Connections

- **Joystick port** In order to generate maps with the Adept Lynx platform, you need to connect a joystick to its Joystick port.  
The Joystick port is located under a small access panel on the left side of the platform, in the upper-right corner.  
This is internally connected to the Joystick port in the payload bay.
- **Maintenance Ethernet** The Maintenance Ethernet port is located under a small access panel on the left side of the platform, in the upper-right corner.  
Its IP address is 1.2.3.4, with Netmask 255.255.255.0.  
Access to the SetNetGo OS is always enabled on this interface, and does not require a password or a license.  
This is internally connected to the Maintenance Ethernet port in the payload bay.
- **Wireless Ethernet** For multi-AIV installations, or where you wish to send new commands or receive status updates from the AIV, you need to have wireless Ethernet.
- **Docking Station** The AIV needs access to a docking station so it can charge itself.

## 5.2 Payload Bay Connections

These connections are available for use with Adept- and user-supplied accessories. The antennas and joystick come with the platform.

**NOTE:** Standard connectors, such as Ethernet and audio, are not covered here. This includes all of the connectors on the right side of the core, shown in the following figure:

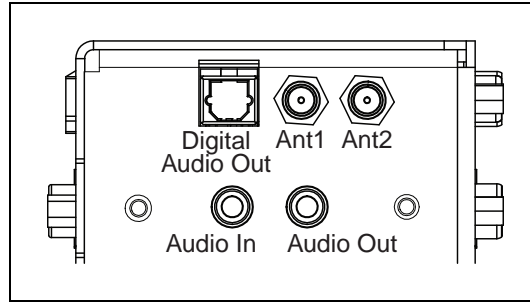

Figure 5-1. Right Side of the Core

### Lynx Core Front, Upper

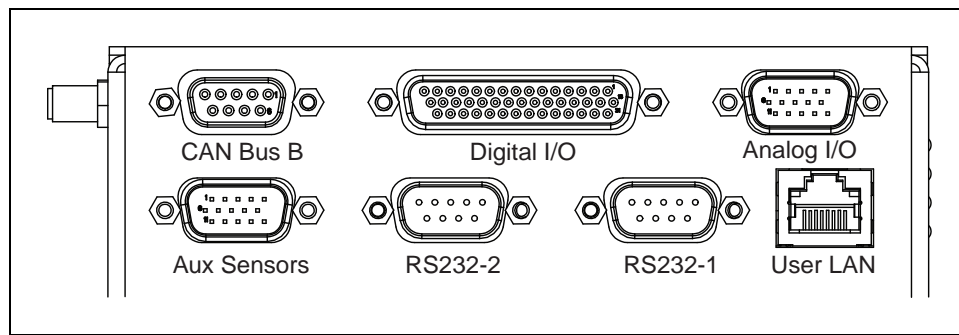

Figure 5-2. Front Upper Core

Connection	Type	Description
Ethernet	RJ45, Shielded	General (USER LAN), Auto-MDIX.
RS-232 (Aux Sensors)	HDB15M	Optional vertical lasers
RS-232 x 2	DB9M	Port 1 and Port 2, general use
CAN Bus B	DB9F	Consult Adept for use.
Digital I/O (HDB44F)	HDB44F	<p>16 digital inputs, in 4 banks of 4. Each bank can be wired as active high or active low depending on the connection of the BANK# terminal.</p> <p><math>V_{IN}</math> range for each input is 0 to 30 V. The input is ON when <math>V_{IN} &gt; 4</math> V, OFF when <math>V_{IN} &lt; 1.3</math> V.</p> <p>16 digital outputs, protected low-side (open-drain) drivers. 500 mA output each. May be used with loads connected to VBAT, AUX_20V, _12V, or _5V. You must stay within the allowed current capacity of the VBAT or AUX power supplies.</p>
Analog I/O	HDB15M	General use



**CAN Bus B**

Connector type DB9F

Use CAN Bus

Pin No.	Designation	Notes
1, 4, 8	No Connection	
2	CANL_B	CAN Communication differential pair
3, 6	GND	Direct GND
5	SHIELD GND	Bead filter to GND
7	CANH_B	CAN Communication differential pair
9	CANB_12V_OUT_SW	12 V @ 0.5 A Max (switched in SW)

**Digital I/O**

Connector type HDB44F

Pin No.	Designation		Notes
	Hardware	Software	
1	INPUT_1.1	Input_1.1	0 – 30 V Range, $R_{in} = \sim 3.9 \text{ k}\Omega$
2	INPUT_1.2	Input_1.2	0 – 30 V Range, $R_{in} = \sim 3.9 \text{ k}\Omega$
3	INPUT_1.3	Input_1.3	0 – 30 V Range, $R_{in} = \sim 3.9 \text{ k}\Omega$
4	INPUT_1.4	Input_1.4	0 – 30 V Range, $R_{in} = \sim 3.9 \text{ k}\Omega$
5	BANK1		Common for INPUT_1.X
6	INPUT_2.1	Input_2.1	0 – 30 V Range, $R_{in} = \sim 3.9 \text{ k}\Omega$
7	INPUT_2.2	Input_2.2	0 – 30 V Range, $R_{in} = \sim 3.9 \text{ k}\Omega$
8	INPUT_2.3	Input_2.3	0 – 30 V Range, $R_{in} = \sim 3.9 \text{ k}\Omega$
9	INPUT_2.4	Input_2.4	0 – 30 V Range, $R_{in} = \sim 3.9 \text{ k}\Omega$
10	BANK2		Common for INPUT_2.X
11	INPUT_3.1	Input_3.1	0 – 30 V Range, $R_{in} = \sim 3.9 \text{ k}\Omega$
12	INPUT_3.2	Input_3.2	0 – 30 V Range, $R_{in} = \sim 3.9 \text{ k}\Omega$
13	INPUT_3.3	Input_3.3	0 – 30 V Range, $R_{in} = \sim 3.9 \text{ k}\Omega$
14	INPUT_3.4	Input_3.4	0 – 30 V Range, $R_{in} = \sim 3.9 \text{ k}\Omega$
15	BANK3		Common for INPUT_3.X

Pin No.	Designation		Notes
	Hardware	Software	
16	INPUT_4.1	Input_4.1	0 – 30 V Range, $R_{in} = \sim 3.9 \text{ k}\Omega$
17	INPUT_4.2	Input_4.2	0 – 30 V Range, $R_{in} = \sim 3.9 \text{ k}\Omega$
18	INPUT_4.3	Input_4.3	0 – 30 V Range, $R_{in} = \sim 3.9 \text{ k}\Omega$
19	INPUT_4.4	Input_4.4	0 – 30 V Range, $R_{in} = \sim 3.9 \text{ k}\Omega$
20	BANK4		Common for INPUT_4.X
21	OUTPUT_1	Output_1	
22	OUTPUT_2	Output_2	
23	OUTPUT_3	Output_3	
24	OUTPUT_4	Output_4	
25	OUTPUT_5	Output_5	
26	OUTPUT_6	Output_6	
27	OUTPUT_7	Output_7	
28	OUTPUT_8	Output_8	
29	OUTPUT_9	Output_9	
30	OUTPUT_10	Output_10	
31	OUTPUT_11	Output_11	
32	OUTPUT_12	Output_12	
33	OUTPUT_13	Output_13	
34	OUTPUT_14	Output_14	
35	OUTPUT_15	Output_15	
36	OUTPUT_16	Output_16	
37	VBAT_IO_OUT4		VBAT @ 0.5 A Max (shared with light pole)
38	VBAT_IO_OUT3		VBAT @ 0.5 A Max
39	VBAT_IO_OUT2		VBAT @ 0.5 A Max
40	VBAT_IO_OUT1		VBAT @ 0.5 A Max
41, 42, 43, 44	GND		

Table 5-1. Digital Input Specifications

Parameter	Value
Operational voltage range	0 to 30 VDC
OFF state voltage range	0 to 1.3 VDC
ON state voltage range	4 to 30 VDC
Operational current range	0 to 7.5 mA
OFF state current range	0 to 0.5 mA
ON state current range	1.0 to 7.5 mA
Impedance ( $V_{in}/I_{in}$ )	3.9 k $\Omega$ minimum
Current at $V_{in} = +24$ VDC	$I_{in} \leq 6$ mA

**NOTE:** The input current specifications are provided for reference. Voltage sources are typically used to drive the inputs.

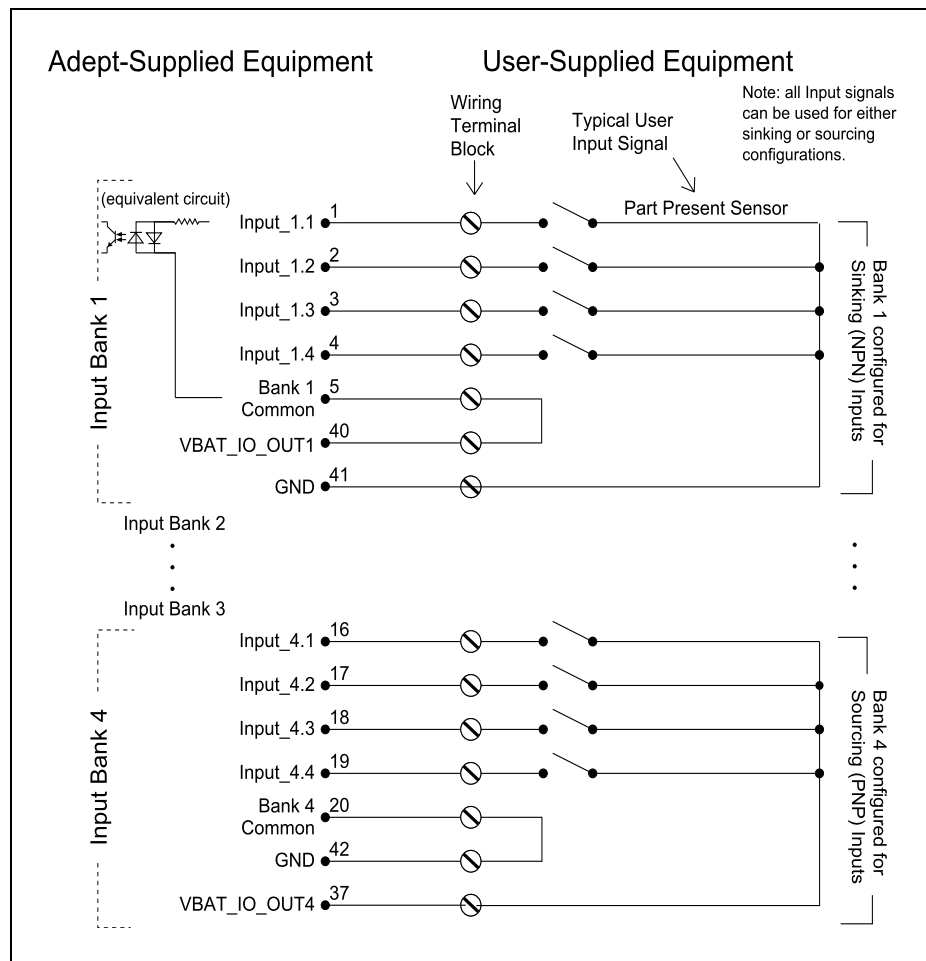

Figure 5-3. Typical Digital Input Wiring Example

Table 5-2. Digital Output Specifications

Parameter	Value
Power supply voltage range	5 - 30 VDC
Operational current range, per channel	$I_{out} \leq 500 \text{ mA}$
ON state resistance ( $I_{out} = 0.5 \text{ A}$ )	$R_{on} \leq 0.14 \Omega @ 85^\circ \text{ C}$
Output leakage current	$I_{out} \leq 5 \mu\text{A}$
DC short circuit current limit	$0.7 \text{ A} \leq I_{LIM} \leq 1.7 \text{ A}$

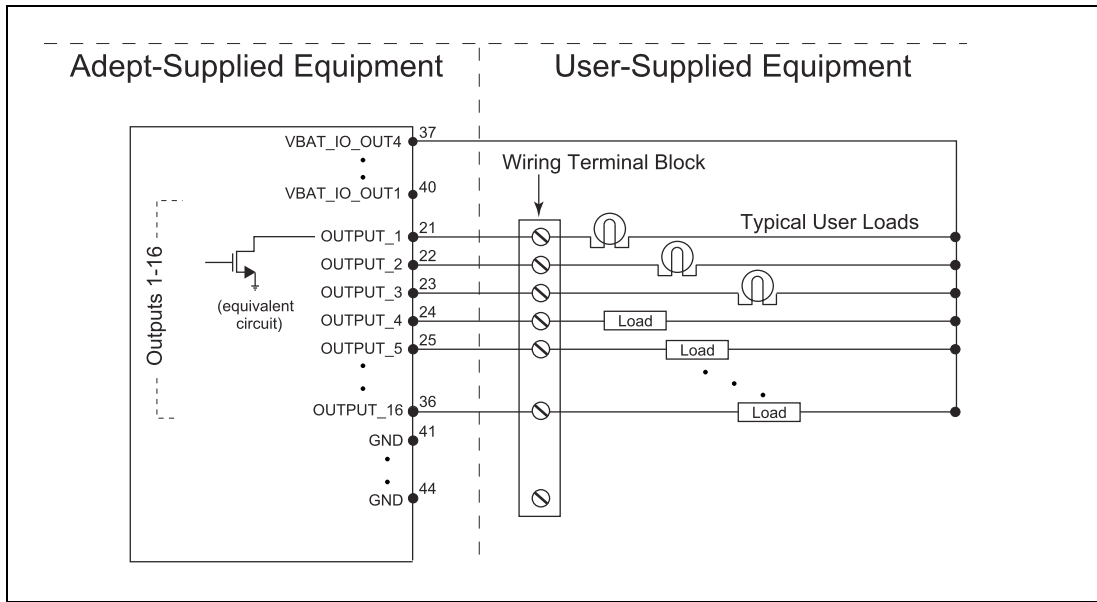

Figure 5-4. Typical Digital Output Wiring Example

**Analog I/O**

Connector type HDB15M

Pin No.	Designation	Notes
1	ANALOG_IN1	0 - 10 V Range, $R_{in} = \sim 35 \text{ k}\Omega$
2	ANALOG_IN2	0 - 10 V Range, $R_{in} = \sim 35 \text{ k}\Omega$
3	ANALOG_IN3	0 - 10 V Range, $R_{in} = \sim 35 \text{ k}\Omega$
4	ANALOG_IN4	0 - 10 V Range, $R_{in} = \sim 35 \text{ k}\Omega$
5	ANALOG_IN5	0 - 30 V Range, $R_{in} = \sim 110 \text{ k}\Omega$

Pin No.	Designation	Notes
6	ANALOG_IN6	0 – 30 V Range, $R_{in} = \sim 110 \text{ k}\Omega$
7	ANALOG_IN7	0 – 30 V Range, $R_{in} = \sim 110 \text{ k}\Omega$
8	ANALOG_IN8	0 – 30 V Range, $R_{in} = \sim 110 \text{ k}\Omega$
9	ANALOG_OUT1	0 – 20 V Range, $\pm 10 \text{ mA}$ , $R_o = \sim 200 \Omega$
10	ANALOG_OUT2	0 – 20 V Range, $\pm 10 \text{ mA}$ , $R_o = \sim 200 \Omega$
11	ANALOG_OUT3	0 – 20 V Range, $\pm 10 \text{ mA}$ , $R_o = \sim 200 \Omega$
12	ANALOG_OUT4	0 – 20 V Range, $\pm 10 \text{ mA}$ , $R_o = \sim 200 \Omega$
13, 14, 15	GND	

### Aux Sensors

Connector type HDB15M

Use Optional vertical lasers

Pin No.	Designation		Notes
	Hardware	Software	
1	RS232_VERT1_TXD		
2	RS232_VERT2_TXD		
3	RS232_FOOT_TXD		
4	5V_SW1	USB_1_and_2_Power	5 V @ 1 A (shared with USB port 1)
5, 10	SW_20V_VERT	Vertical_Laser_Power	20 V @ 300 mA
6, 7, 8	GND		
9	5V_SW2	USB_1_and_2_Power	5 V @ 1 A (shared with USB port 2)
11	RS232_VERT1_RXD		
12	RS232_VERT2_RXD		
13	RS232_FOOT_RXD		
14	5V_SW3	USB_3_Power	5 V @ 1 A (shared with USB port 3)
15	SW_20V_FOOT	Foot_Laser_Power	20 V @ 150 mA

### RS232 1 & 2

Connector type DB9M

Use Port 1 and 2, General Use

Pin No.	Designation	Notes
1, 4, 6, 9	No Connection	
2	RS232_USR#_RXD	# = 1 or 2
3	RS232_USR#_TXD	# = 1 or 2
5	GND	
7	RS232_USR#_RTS	# = 1 or 2
8	RS232_USR#_CTS	# = 1 or 2

### Lynx Core Rear, Upper

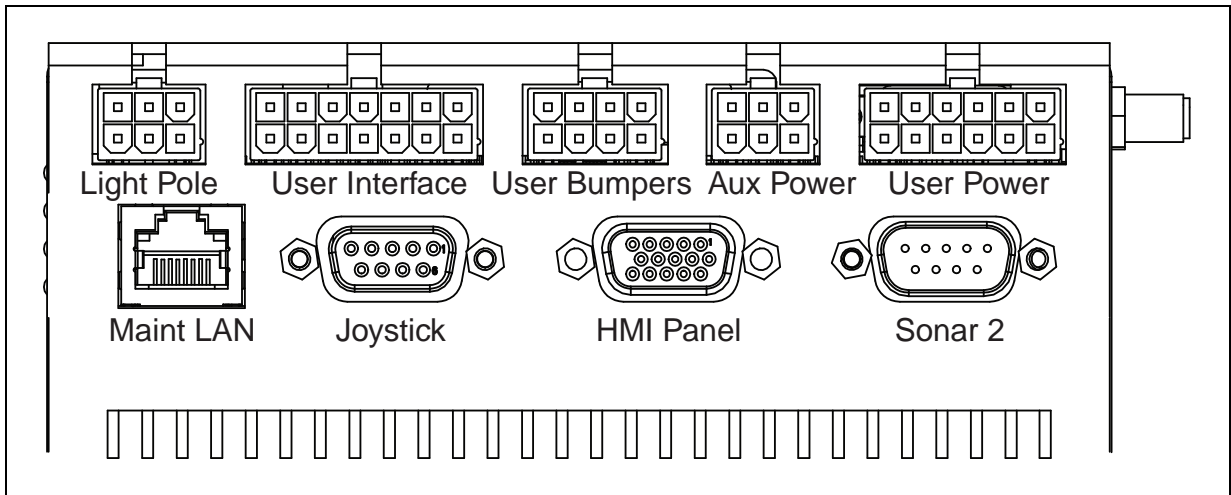

Figure 5-5. Rear Upper Core

Connection	Type	Description
Light Pole	Mini-Fit2 x 3	Connects to a user-supplied light tower with 3 lights and 1 buzzer, using a default configuration
<b>NOTE:</b> The following four functions are pins on the User Interface connector.		
Brake-release	Mini-Fit 2 x 7	Pins for user-supplied brake release
ON		Pins for user-supplied ON button; same function as Operator Panel ON
OFF		Pins for user-supplied OFF button; same function as Operator Panel OFF
ESTOP		Pins for user-supplied E-Stop
User Bumpers	Mini-Fit 2 x 4	Payload bumpers, user-supplied, connected between ESTOP_SRC and USER_BMP# (for each of the 6 inputs). Contacts should be 12 V @ 10 mA.

Connection	Type	Description
Aux Power	Mini-Fit 2 x 3	5, 12, and 20 VDC Outputs
User Power	Mini-Fit 2 x 6	Battery and switched battery power
Maintenance Ethernet	RJ45, Shielded	Directly connected to the externally-mounted Maintenance Ethernet, Auto-MDIX.
Joystick	DB9F	Directly connected to the externally-mounted Joystick port
HMI Panel	HDB15F	Operator screen, E-Stop, Brake_Rel, ON, OFF
Sonar #2	DB9M	Optional sonar (x8) for payload

### Power Connections

The Lynx platform provides conditioned 5, 12, and 20 VDC, and raw (battery) 22 - 30 VDC power to the platform's and accessory electronics, including the onboard Lynx core and safety scanning laser LIDAR (Light Detection And Ranging).

All power connectors are Mini-Fit®.

Nominal	Qty	Actual	Maximum Current	Description
5 VDC	1	5 VDC	1 A	Switched Aux power
12 VDC	1	12 VDC	1 A	Switched Aux power
20 VDC	1	20 VDC	1 A	Switched Aux power
22 - 30 VDC	2	battery	4 A	Switched
22 - 30 VDC	1*	battery	10 A	Switched
22 - 30 VDC	1*	battery	10 A	Safe, Switched
* 10 A Switched and 10 A Safe, Switched share the 10 A of current.				

Each supply has an associated LED which, when lit, indicates that the port is actively powered. See Lynx Core Indicators on page 77.

The Safe 22 - 30 VDC supply automatically gets disconnected when the E-Stop button is pressed, an obstacle is detected, or the bumper touches something.

### Light Pole (user-supplied)

Connector type Mini-Fit® 3 x 2

Use Light tower

Pin No.	Designation	Notes
1	GND	
2	LIGHT_P1	

Pin No.	Designation	Notes
3	LIGHT_P2	
4	VBAT_IO_OUT4	VBAT @ 0.5A Max (shared with DIO)
5	LIGHT_P3	
6	LIGHT_P4	

**NOTE:** Light 4 is the buzzer on the light tower.

### User Interface

Connector type Mini-Fit® 7 x 2

Use Brake release, ON, OFF, E-Stop

Pin No.	Designation	Notes
1, 2, 3	FBAT_ALWAYS	Fused VBAT @ 500 mA
4	ESTOP_USR_1L	Short 4 & 11 to close ESTOP_USR_1
5	ESTOP_USR_2L	Short 5 & 12 to close ESTOP_USR_2
6	ESTOP_OUT_1L	Pins 6 & 13 short when ESTOP_CH1 is closed
7	ESTOP_OUT_2L	Pins 7 & 14 short when ESTOP_CH2 is closed
8	OFF_BUTTON	Short to FBAT_ALWAYS to signal OFF (min 1 s pulse)
9	START_BUTTON	Short to FBAT_ALWAYS to signal ON (min 1 s pulse)
10	MOTOR_BRAKE	Short to FBAT_ALWAYS for manual brake release
11	ESTOP_USR_1H	Short 4 & 11 to close ESTOP_USR_1
12	ESTOP_USR_2H	Short 5 & 12 to close ESTOP_USR_2
13	ESTOP_OUT_1H	Pins 6 & 13 short when ESTOP_CH1 is closed
14	ESTOP_OUT_2H	Pins 7 & 14 short when ESTOP_CH2 is closed

**NOTE:** An E-Stop jumper or a user-supplied E-Stop button needs to be attached to the E-STOP port on the User Interface connector for the platform to function. The jumper is provided as part number 12730-000L. An E-Stop button would be user-supplied.



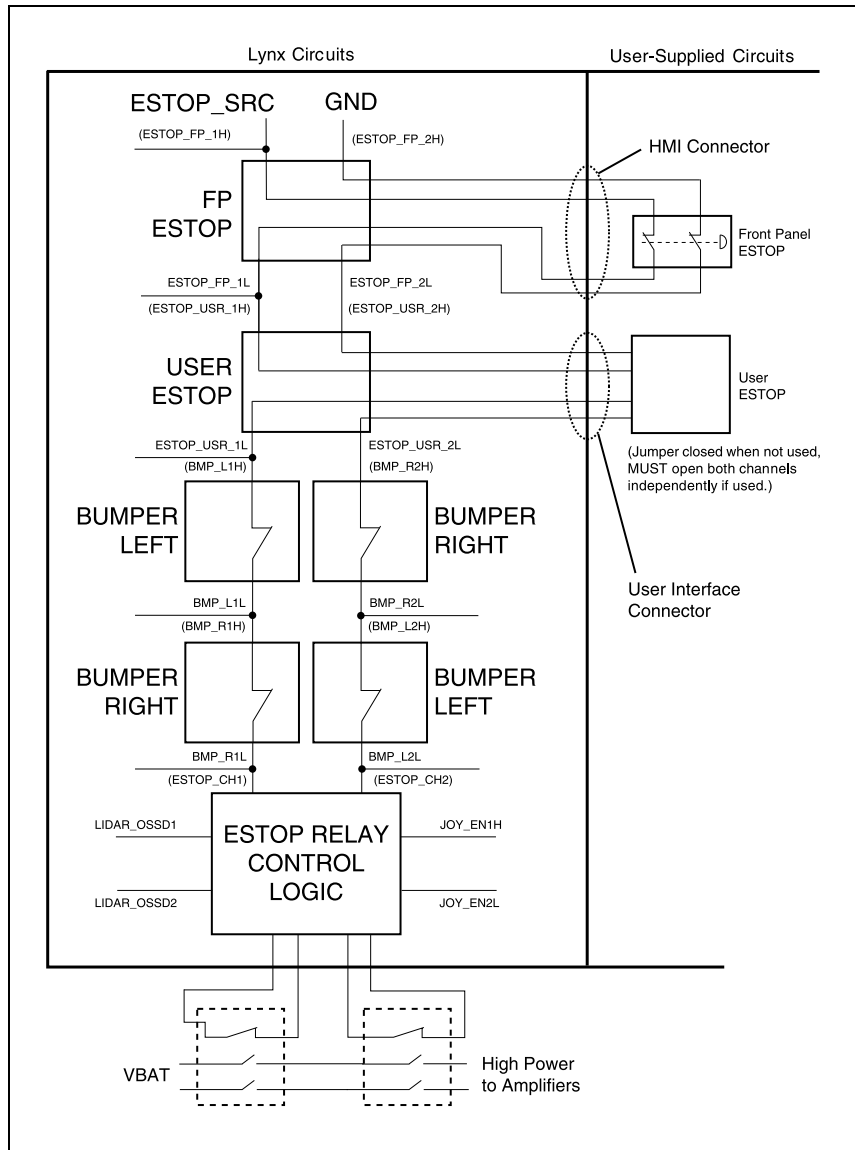

Figure 5-6. E-Stop Chain Diagram

**User Bumper**

Connector type Mini-Fit® 4 x 2

Use Optional bumper (x8) for payload

Pin No.	Designation	Notes
1	USER_BUMPER_1	Short to ESTOP_SRC to signal bumper hit
2	USER_BUMPER_2	Short to ESTOP_SRC to signal bumper hit
3	USER_BUMPER_3	Short to ESTOP_SRC to signal bumper hit
4	USER_BUMPER_4	Short to ESTOP_SRC to signal bumper hit
5	USER_BUMPER_5	Short to ESTOP_SRC to signal bumper hit
6	USER_BUMPER_6	Short to ESTOP_SRC to signal bumper hit
7, 8	ESTOP_SRC	12 V ESTOP Source Output @ 10 mA

**Aux Power**

Connector type Mini-Fit® 3 x 2

Pin No.	Designation		Notes
	Hardware	Software	
1, 2, 3	GND		
4	AUX_5V_OUT	Aux_5V	5 V @ 1 A max
5	AUX_12V_OUT	Aux_12V	12 V @ 1 A max
6	AUX_20V_OUT	Aux_20V	20 V @ 1 A max

**User Power**

Connector type Mini-Fit® 6 x 2

Pin No.	Designation		Notes
	Hardware	Software	
1, 2, 3, 4, 5, 6	GND		Limit to < 5 A per pin
7	SW_VBAT_OUT1	Battery_Out_1	VBAT @ 4 A max (switched in SW)
8	SW_VBAT_OUT2	Battery_Out_2	VBAT @ 4 A max (switched in SW)
9, 10*	SW_VBAT_OUT34	Battery_Out_3_and_4	VBAT @ 10 A max (switched in SW). Limit to < 5 A per pin.
11, 12*	SAFE_VBAT_OUT		SW_VBAT_OUT34 gated by dual-channel ESTOP relays.
*9,10 and 11,12 share the 10 A of current.			

**Joystick**

Connector type DB9F

Use Joystick

Pin No.	Designation	Notes
1	JOY_XAXIS	Analog X input
2	JOY_YAXIS	Analog Y input
3	JOY_SPEED	Analog SPEED input
4	JOY_GOAL	Goal Button Input
5	JOY_EN_1H	Enable channel 1
6	JOY_EN_2L	Enable channel 2
7	No Connection	
8	GND	
9	5V	5 V @ 100 mA

**HMI Panel**

Connector type HDB15F

Use Operator screen, E-Stop, Brake\_Rel, ON, OFF

Pin No.	Designation		Notes
	Hardware	Software	
1	RS422_HMI_TX+		Connections to Adept HMI Panel
2	RS422_HMI_TX-		
3	MOTOR_BRAKE		
4, 5	ESTOP_FP_1H, _2H		
6	RS422_HMI_RX+		
7	RS422_HMI_RX-		
8	START_BUTTON		
9, 10	ESTOP_FP_1L, _2L		
11	HMI_5V_SW	HMI_Power	
12, 14	GND		
13	OFF_BUTTON		
15	FBAT_ALWAYS		

**Sonar 1 & 2**

Connector type DB9M

Use Platform sonar & optional sonar (x8) for payload

**NOTE:** Sonar 1 is part of the Internal Lynx Core connections.

Pin No.	Designation		Notes
	Hardware	Software	
1, 4, 8	No Connection		Connections to Adept Sonar Module # = 1 or 2
2	RS422_SNR_RX+		
3	RS422_SNR_TX+		
5	GND		
6	RS422_SNR_RX-		
7	RS422_SNR_TX-		
9	SW_12V_SNR	Sonar_#_Power	

### 5.3 Internal Lynx Core Connections

The following connections are internal (under the platform's top deck), and not normally available for the user. They are listed here so that you can reconnect them in the event that they need to be disconnected for parts replacement.

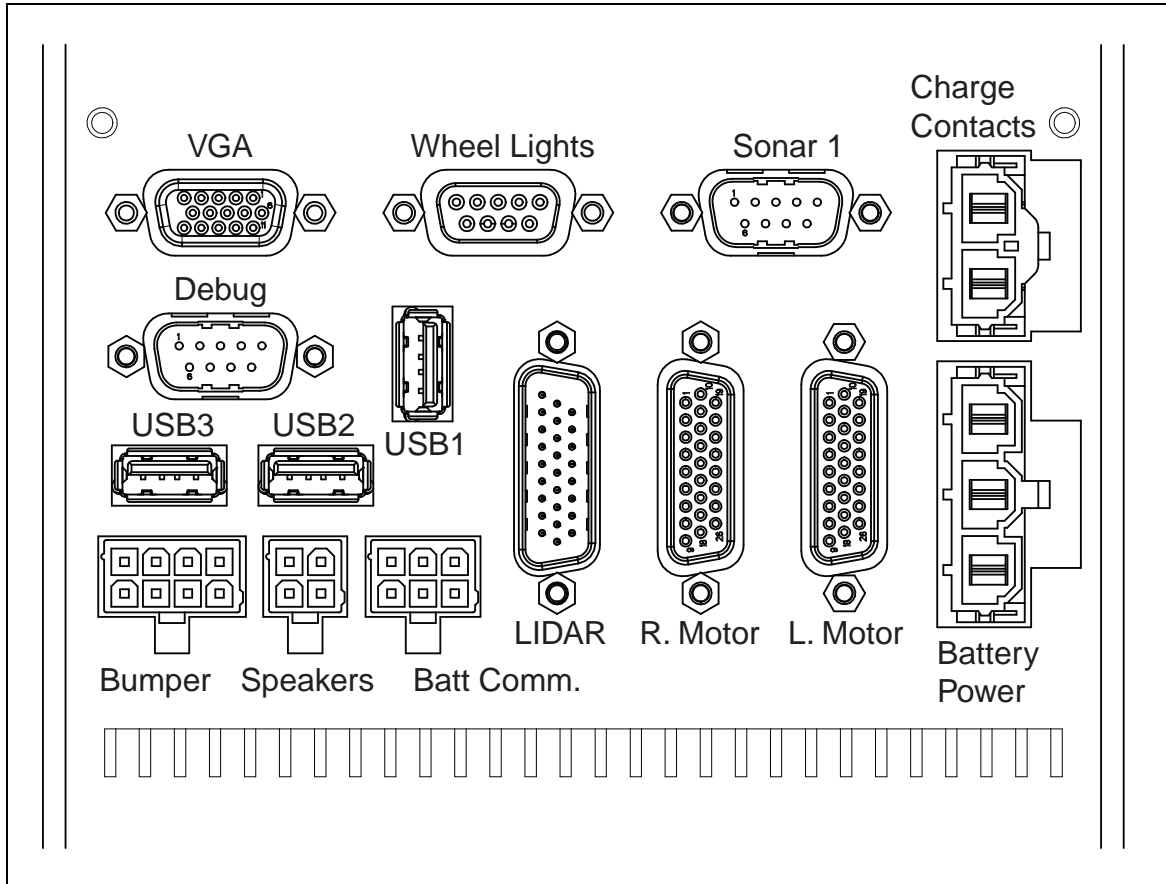

Figure 5-7. Internal Connectors on the Lynx Core (Front)

Connection	Type	Description
VGA	HDB15F	Reserved
Wheel Lights	DB9F	Motion and status indicator light discs on the platform sides
Sonar # 1, RS-422	DB9M	Connection to Adept Sonar Module (Front bumper and rear sonar sensors)
Charge Contacts	Mini-Fit Sr., 2-pin	
Debug RS-232	DB9M	Reserved
USB x 3	USB Type A	Reserved
LIDAR	HDB26M	Safety Scanning Laser

Connection	Type	Description
Right Motor	HDB26F	<b>NOTE:</b> The Right and Left Motor connectors use the same type of plug. Take care not to reverse them.
Left Motor	HDB26F	
Battery Power	Mini-Fit Sr., 3-pin	Battery VDC; connects to battery
Bumper Switches	Mini-Fit 2 x 4	Connect to standard bumper contacts
Speakers	Mini-Fit 2 x 2	Drives built-in speakers
Battery Comm.	Mini-Fit 2 x 3	Battery communication/control

## Lynx Internal Data Pinouts

### Wheel Lights (Light Discs)

Connector type DB9F

Use Motion and status indicator light discs on the platform sides

Pin No.	Designation		Notes
	Hardware	Software	
1, 2	CANL_A		CAN Communication differential pair
3, 4	GND		Direct GND
5	SHIELD GND		Bead filter to GND
6, 7	CANH_A		CAN Communication differential pair
8, 9	SW_12V_WHEEL	WheelLight_Power	12 V @ 1 A Max (switched in SW)

**NOTE:** Sonar 1 is covered at the end of Core, Upper Rear.

**LIDAR (Light Detection And Ranging)**

Connector type DB26M

Use Front safety scanning laser

Pin No.	Designation		Notes
	Hardware	Software	
1	RS422_LIDAR_RX+		Connections to Adept-Supplied LIDAR
2	RS422_LIDAR_RX-		
3	OSSD1		
4	OSSD2		
5	WF_OUT		
6	O3_OUT		
7	STANDBY		
8	EDM		
9	No Connection		
10, 18	SW_20V_LIDAR	Main_Laser_Power	
11 thru 17	GND		
19	RS422_LIDAR_TX+		
20	RS422_LIDAR_TX-		
21	IN_A1		
22	IN_A2		
23	IN_B1		
24	IN_B2		
25	IN_C1		
26	IN_C2		

Pin 10 + 18: Current &lt; 600 mA

## Lynx Internal Power Pinouts

### Bumper

Connection	Mini-Fit® 4 x 2
Connector type	DB9F
Use	Front bumpers

Pin No.	Designation	Notes
1	BUMPER_R2L	Right, Channel 2, Low
2	BUMPER_R1L	Right, Channel 1, Low
3	BUMPER_L2L	Left, Channel 2, Low
4	BUMPER_L1L	Left, Channel 1, Low
5	BUMPER_R2H	Right, Channel 2, High
6	BUMPER_R1H	Right, Channel 1, High
7	BUMPER_L2H	Left, Channel 2, High
8	BUMPER_L1H	Left, Channel 1, High

### Speakers

Connector type	Mini-Fit® 2 x 2
Use	Speakers

Pin No.	Designation	Notes
1	RIGHT+	Right Speaker
2	RIGHT-	
3	LEFT+	Left Speaker
4	LEFT-	



**Batt Comm.**

Connector type Mini-Fit® 3 x 2

Use Battery control

Pin No.	Designation	Notes
1	GND	Connections to the Adept-Supplied Battery
2	RS232_BATT_RXD	
3	RS232_BATT_TXD	
4	FBAT_ALWAYS	
5	START_BUTTON	
6	OFF_BUTTON	



# Chapter 6: Operation

---

Before proceeding, you need to have performed the steps covered in the Setup and Getting Started chapters, so your platform has a map to work from.

## 6.1 Operating Environment

The Adept Lynx platform is designed to operate in an environment that is wheelchair accessible. Care must be taken to avoid:

- glass doors and walls
- pits without railings or low bumpers
- floors with access panels removed
- loose cables, hoses, etc.
- large, highly-reflective objects

Floors must provide good traction, typical of good walking conditions.

- Slope up to 1:12
- Step traversal up to 15 mm (0.6 in.)
- Gap traversal up to 15 mm (0.6 in.)
- Temperature 5° to 40° C (41° to 104° F)
- Humidity 5 to 95%, non-condensing

The Adept Lynx platform is not intended for use in hazardous environments (explosive gas, water, dust, oil mist). It has an IP rating of IP-44.

## 6.2 Typical Operation

During normal startup, your Adept Lynx platform powers all its onboard systems<sup>1</sup> and runs its onboard software and your integrated processes automatically to provide an application-ready AIV. If it has been given a map of its workspace and knows where it is within that environment (localized), your AIV is ready to perform on startup and will operate autonomously, without human intervention.

The following applications are covered in detail in the [Adept Motivity® User's Guide](#).

There are many options for configuring and tuning your Adept Lynx platform to best suit your application.

Maps are developed with the MobilePlanner application. These may contain a variety of virtual elements, including special lines and sectors which act to modify the behavior of an

---

<sup>1</sup>As configured either by the factory or through your own parameter changes.

Adept Lynx platform. Virtual elements include forbidden lines and areas, speed zones, preferred-direction zones, and more, all working to help you configure your platform's workspace for efficient and safe performance of your mobile application. You can also create your own virtual elements for application-specific AIV-workspace interactions.

Maps contain a variety of goals, routes, and tasks that comprise the destinations and activities of the AIV in the workspace.

Paths are not pre-programmed, but instead are generated dynamically onboard the platform. Paths are updated many times per second to maintain a smooth trajectory and to account for any obstacles that are detected by the onboard sensors. Navigational parameters are stored onboard the platform, and can be viewed and modified using the MobilePlanner software. The MobilePlanner software is covered in the [Adept Motivity® User's Guide](#).

The MobilePlanner application, running on your computer, is used to configure the many high-level operating characteristics of the platform, including speeds and accelerations, sensor safety zones, minimum battery level allowed before docking for recharging, which map to use, and many other parameters. The MobilePlanner software typically communicates with the platform over the wireless network. A direct connection, through the maintenance Ethernet port on the platform, is also possible.

### 6.3 Power and Charging

The Adept battery is sealed. It supplies ample power for the motors, electronics, and accessories.

The platform ships separately from the battery. The battery is shipped fully-charged. You should have installed the battery in the platform in Setup on page 19.

Battery recharging is managed by the platform. With ample power, as is provided by the automated docking station, all onboard systems function continuously while the battery recharges.

The Operator screen shows % state-of-charge (SOC) remaining for battery.

Run-time, with no load, is approximately 13 hours. This will vary significantly depending on use and accessory power consumption.

Recharge time is approximately 3.5 hours.

#### Battery Indicators and Controls

The battery has one push-button and four LEDs. From left to right, they indicate:

LED	Color	Meaning
1	Red	Error condition
	Green	25% state of charge
2	Green	50% state of charge
3	Green	75% state of charge
4	Green	100% state of charge

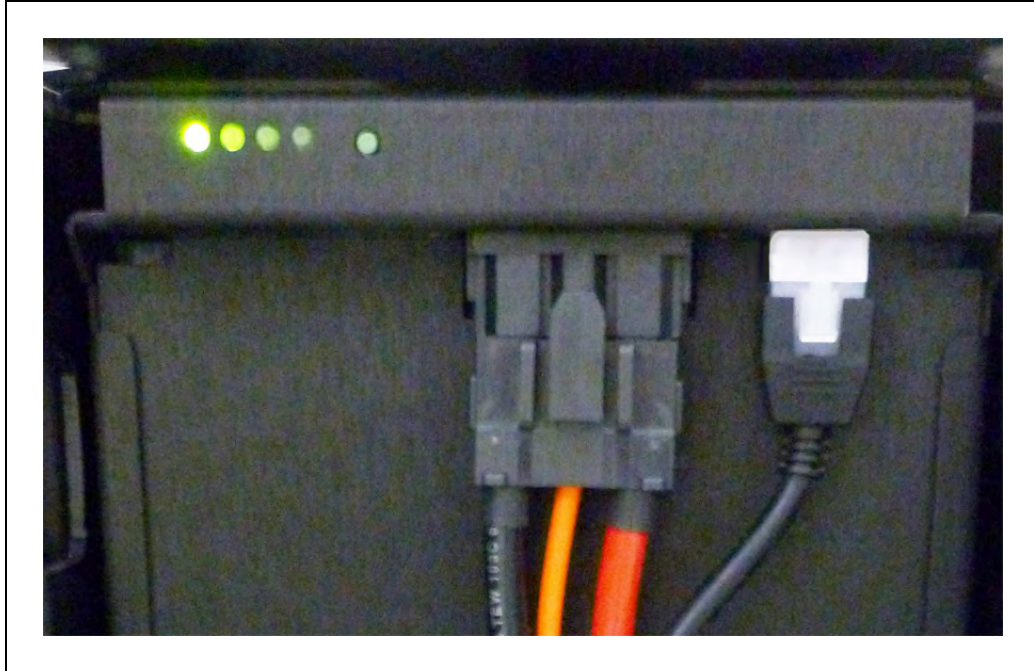

Figure 6-1. Battery LEDs, Push-Button, Power Cable, and Data Cable

The push-button "wakes up" the battery, so it displays its state of charge. This can be useful when a battery is in storage, and you need to know its state of charge.

### Automated Docking Station

The automated docking station is both a manual and an automated means for recharging your battery.

During normal, autonomous operation of the Adept Lynx AIV in the workspace, the AIV manages charging automatically through the automated docking station. The AIV will approach the docking station frontward, and then turn around and back onto the docking station to charge. There is up to a 10-second delay between when a AIV docks and when the charging LED turns on.

Powering ON or OFF the AIV, or connecting and disconnecting the AIV with network and onboard clients will not disturb the charging state. (Moving the AIV will, of course.) The station supplies ample power for all onboard systems while charging its battery, so you can continue operating those systems while charging.

If the AIV is powered off, it will turn on automatically when it is pushed onto the docking station. An AIV cannot be turned off while on the docking station.

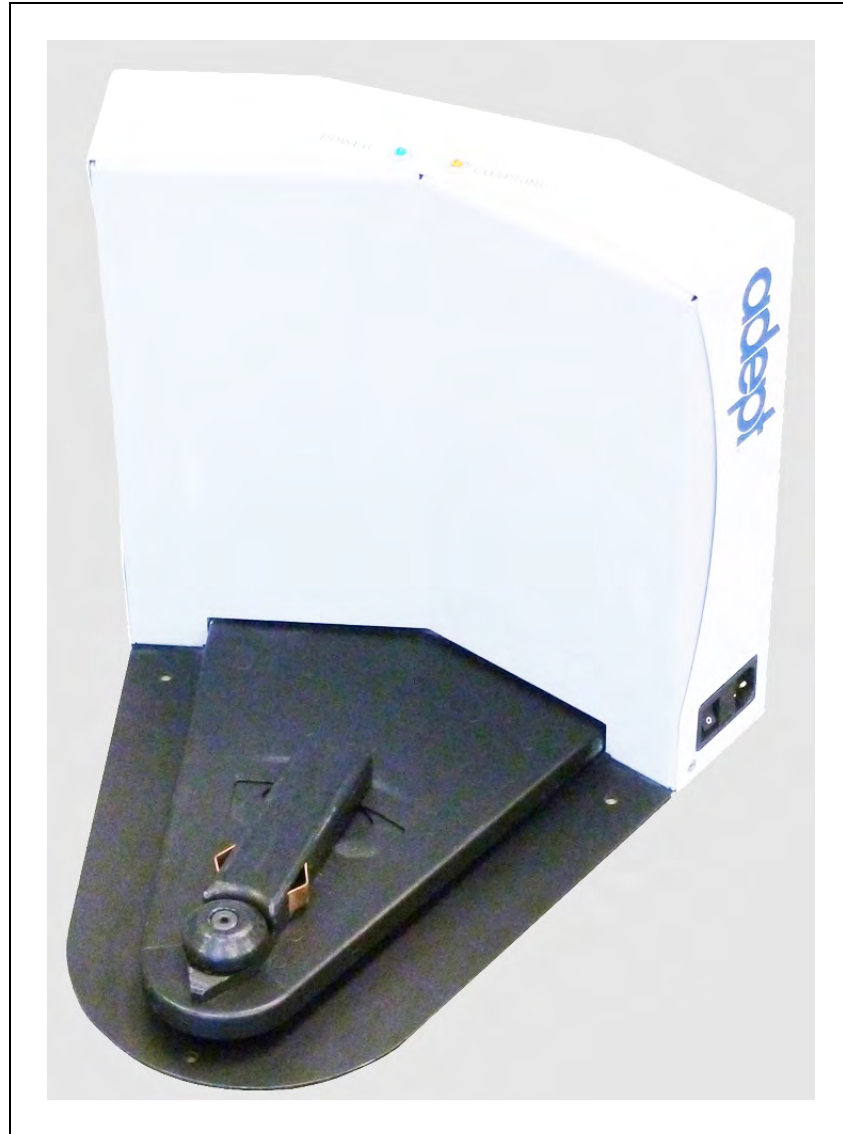

Figure 6-2. Docking Station

### **Indicators, Controls, and Connections**

The docking station has a power switch and two LEDs:

- blue indicates that power is available.
- yellow indicates that a charge is in progress.

The power plug for AC supply is on the right side of the station, as viewed from the front. Power requirements are 100 - 240 VAC, 50 - 60 Hz, and 8 A.

The plug for connecting the manual charging cable is on the left side of the station, as viewed from the front.

### **Environmental Requirements**

- Ambient temperature range: 5° to 40° C (41° to 104° F)
- Humidity: 5 to 95% non-condensing

### **Maintenance**

The docking station contacts should be cleaned quarterly with isopropyl alcohol. See Docking Station Contacts on page 85.

The guide roller can be replaced in the field. See Docking Station Roller and Bearing on page 94.

If necessary, the height of the docking station contacts can be adjusted. See Docking Station Contact Adjustment on page 34.

### **Manually Charging the Battery**

#### **Inside the Platform**

To manually charge a battery inside the platform, push the AIV backwards, with E-STOP engaged, so that the rear of the platform slides over the contacts of the docking station.

**NOTE:** You will need to press the brake release button first.

#### **Outside the Platform**

The battery can be charged, outside of the platform, by using the connector on the left side of the docking station (viewed from the front) with the provided charging cable. This will most likely be used for charging a spare battery, while the second battery is still in the platform, and the platform is in use.

There is up to a 10-second delay between when you connect the battery cable and when the charging LED turns on.

**NOTE:** The docking station cannot charge a platform and a separate battery at the same time. If a platform is at the station, the power to the manual charge connector is cut off.

## **6.4 Operator Panel**

The Operator panel comprises a screen, an E-Stop button, ON and OFF buttons, a brake-release button, and a keyswitch. The panel will typically be mounted on the payload, so that it is easily reached by an Operator.

### **Screen**

The screen is a color TFT, 320 x 240 pixels, 3.5 in. diagonal. It can display 256K colors, and is backlit.

**NOTE:** Tapping lightly on the screen will turn on the backlight, in case it has timed out.

**Default/Sample Screen Contents**

The first screen, during boot-up, will be the following:



Figure 6-3. Initial Boot Screen

Once the Lynx platform is booted, you will see the main screen:



Figure 6-4. Fields of the Main Screen



- Up to six messages will be displayed in the main screen, in order of importance.
- Only one fault at a time will be displayed.
- Any event or condition that causes an ARAM restart or AIV shut down will be displayed, giving the cause of the restart or shut down.

## E-Stop

When pressed, the red, latching push-button removes power from the platform's motors and from the E-Stop power port after a 1 second delay, giving the software time to stop the platform gently. To reset the E-Stop, twist the button slightly, so it pops up.

The motors must also be explicitly enabled, either with the dialog box that will pop up or with the ON button. (This is not the case if the AIV is docked or experienced a critical driving fault.) This can be done either with the MobilePlanner (with **Map > Show Robot** on) or MobileEyes software, or with an ARCL command. See the following figure:

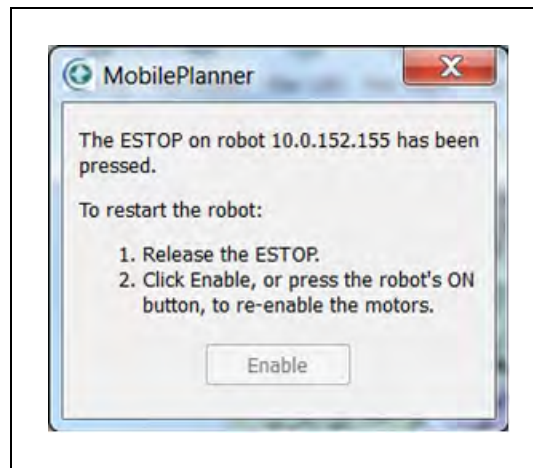

Figure 6-5. Motor Enable Pop-up Dialog

There is, in fact, a second pop-up that will say the E-Stop has been cleared, and you need to click Enable to re-enable the motors.

## ON Button

The ON button is used for restoring power after the OFF button has been pressed, and the software has finished shutting down the AIV.

It can also be used to restore power after an E-Stop has been pressed.

## OFF Button

The red OFF button removes power from all systems except the charging hardware circuits. The platform's software systems prevent loss of data on shutdown, and save the platform's last known location so it automatically localizes when it is next powered on.

**NOTE:** The OFF button can be disabled by the keyswitch, which can be locked.

## Brake-release Button

The brake-release is used when you need to manually move the platform.

## Keyswitch

The keyswitch can be used to disable the OFF button. The key can be removed in either the locked or unlocked positions.

## 6.5 Other Controls and Indicators

### Light Discs, Light Tower

Circular lights on the sides of the platform are used to indicate motion, turns, and several other states. A user-supplied light tower can be added for extra signaling.

Their states are described here, and summarized in the following tables.

#### **Stopped, no errors (ready)**

Entire light disc on each side pulses blue slowly (0.25 Hz). Light tower is steady green.

#### **Driving Straight**

Blue arcs on each side of the platform will appear to rotate in the direction of the platform's travel, to let nearby people know that it is moving (or about to move). Light tower is green and buzzer sounds, both intermittently.

#### **Turn Signals (for turns >30 degrees)**

The blue drive indicators will include a blinking orange segment at the front of one light disc to indicate that the platform is about to turn in the direction of the signal.

Light tower is green blinking and intermittent buzzer (same as driving straight).

#### **Obstacle Detected**

The light discs will blink yellow if the Lynx AIV is stopped for an object in its safety zone. Light tower is yellow blinking.

#### **Warning, Driving or Stopped (doesn't prevent driving, such as low battery)**

The light discs will be orange instead of blue for Stopped, Driving, and Turn Signals.

Light tower alternates green with buzzer then yellow if driving, Long green alternates with short yellow if stopped.

#### **Lost**

When the platform is lost, the light discs will each display two orange arcs, traveling from the 6 o'clock to the 12 o'clock position and back, in opposite directions. Light tower blinks yellow.

#### **Charging**

When docked, a green arc will indicate the current state of charge (SOC), showing steady green from the top of the disc to the current SOC. A small white arc travels back and forth between the two ends of the green arc. Light tower is off.

Lynx Left Side	Lynx Right Side	State of Charge
0 to 90 cw	0 to 270 ccw	25%
0 to 180 cw	0 to 180 ccw	50%
0 to 270 cw	0 to 90 ccw	75%
full circle	full circle	100%

### E-Stop

The light discs will blink red in an E-Stop condition. Light tower blinks red.

### Booting

When booting, the light discs will display two blue arcs, traveling from the 6 o'clock to the 12 o'clock position and back, in opposite directions. Light tower alternates green, yellow, then red.

In the following table:

- Blink indicates that a disc/light/buzzer is on for a period, then off for a period.
- Pulse indicates a 0.25 Hz fade on and off.
- Circle indicates that the lights appear to be going in a circle.
- Half-circles indicates two arcs, moving opposite each other between the top and bottom.
- Solid indicates that a light is on, with no off interrupting it.
- Alt indicates that the light tower switches between different lights (and/or buzzer), with no pause. Two lights with Alt means one light is always on, but not two at once.

Table 6-1. Indicator Meanings

	Light Disc		Light Tower		Meaning
	Color	Pattern	Color	Pattern	
1	Blue	Pulse	Green	Solid	Stopped, all ok
2	Blue	Moving Circle	Green+Buzzer	Blink	Driving Straight, all ok
3	Blue/ Orange @front	Moving Circle/ Blinking signal	Green+Buzzer	Blink	Turning > 30 degrees in direction of orange turn signal, all ok
4	Yellow	Blink	Yellow	Blink	Object detected in safety zone
5	Orange	Same as 1,2,3	(Green+Buzzer) /Yellow if driving Green/Green/Green /Yellow if stopped	Alt Alt	Warning, doesn't prevent driving - applies to driving, turning, and stopped e.g. low battery
6	Orange	Left+Right	Yellow	Blink	Lost

	Light Disc		Light Tower		Meaning
	Color	Pattern	Color	Pattern	
		Half-circles			
7	Red	Blink	Red	Blink	E-Stop, stops driving
8	Green/White arc	quarter, half, or three-quarter green arc	no signal	n/a	Charging
9	Blue	Left+Right Half-circles	Green/Yellow/Red	Alt	Booting

## Joystick

The joystick plugs into the left side of the Lynx platform, under the small access panel at the upper-right corner of the platform. See Location of Parts on the Platform on page 83. A second, identical joystick port is located on the rear side of the Lynx core.

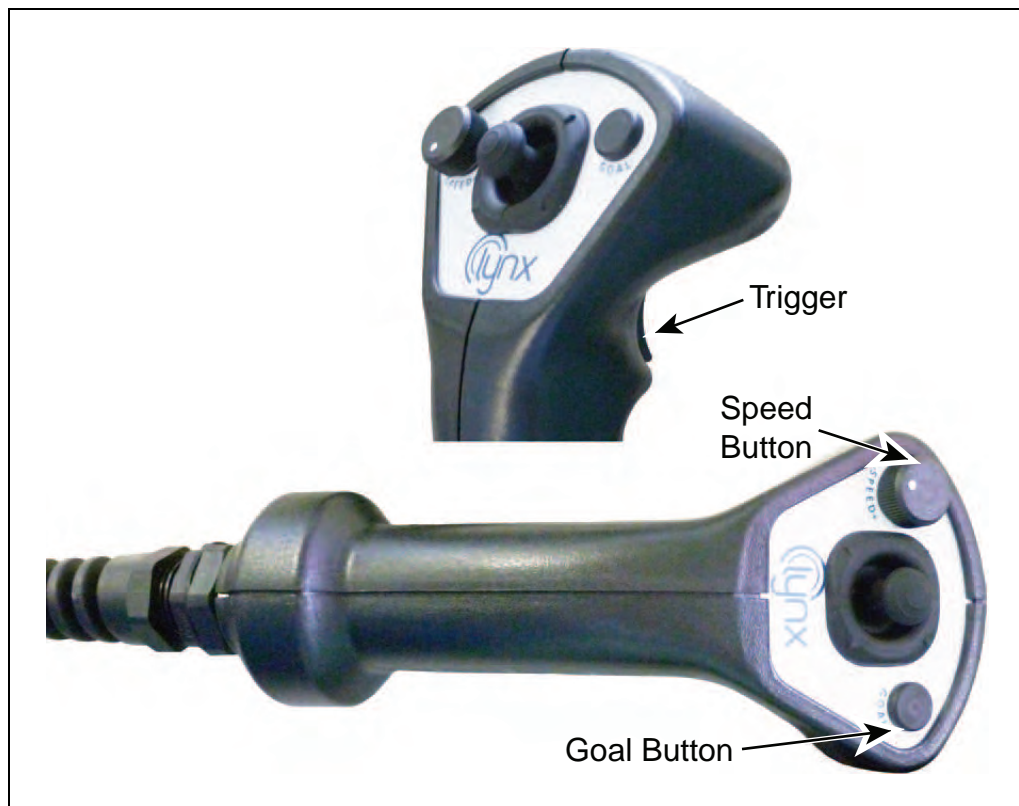

Figure 6-6. Joystick Buttons and Trigger

Use the joystick to drive the Lynx platform manually. Squeeze the trigger to drive.

Push the handle forward or back to make the platform move in that direction. Push the handle to the side to make the platform rotate in that direction. Diagonal positions of the handle drive the platform in an arc.

The Adept Lynx platform slows to a stop when you release the trigger. To stop more quickly, continue to squeeze the trigger and pull or push the joystick handle to its limit in the opposite direction of the platform's travel.

The joystick's GOAL button is for marking positions while making a map scan. When not making maps, press GOAL to enter Follow Mode. See Follow Mode on page 36.



**WARNING:** The Adept Lynx Platform Safety Scanning Laser is not tied into the E-Stop chain when driven using the joystick. The platform will still avoid obstacles detected by the Safety Scanning Laser. The sonar, on the other hand, are disabled entirely when driving with the joystick.

## Maintenance Ethernet

The Maintenance Ethernet port is on the left side of the Lynx platform, under the small access panel at the upper-right corner of the platform. This is internally connected to the Ethernet port located on the rear side of the Lynx core in the payload bay.

The Maintenance Ethernet port is permanently set to IP address 1.2.3.4, with a netmask of 255.255.255.0, for direct, wired access to the onboard systems. Accordingly, when accessing the port, manually set the offboard computer's Ethernet to an IP 1.2.3.x, where x is any number 1 through 254 except 4, and with a netmask of 255.255.255.0. No special DNS or gateway settings are needed.

## Lynx Core Indicators

The left end of the Lynx core has 12 indicator lights. The following table gives their meanings:

Indicator	Meaning
Left Column	
LOGIC	The microcontroller has power
PC	The Lynx core and the servo controller are communicating
DRIVE	The drive wheels are under servo control
ESTOP	An E-Stop has been activated
Middle Column	
20V	20 V power is available
12V	12 V power is available
5V	5 V power is available
VBAT	Raw battery power is available
Right Column	
LAN USER	The USER LAN connector is showing activity
LAN MAINT	The Maintenance Ethernet connector is showing activity
WLAN	The WiFi is showing activity
HD	The hard drive is showing activity

## 6.6 Sensors

### Safety Scanning Laser

The onboard safety scanning laser is a very precise scanning sensor. The laser provides 500 readings in a 250 degree field of view, with a typical maximum range of 15 m (49.2 ft). The laser operates in a single plane, positioned at about 191 mm (7.5 in.) above the floor. In most environments, the sensor will provide highly-accurate data.

Glass, mirrors, and other highly-reflective objects cannot be reliably detected by the laser. Caution must be exercised when operating the platform in areas that have these types of objects. If the platform will need to drive in close proximity of these objects, Adept recommends that you use a combination of markings on the objects, such as tape or painted strips, and also use forbidden sectors in the map, so that the platform knows to plan paths safely around these objects.

### Sonar

#### Rear-Facing

The Adept Lynx platform's four rear-facing sonar are for obstacle-sensing while backing up. The range is up to 5 m (16 ft), though the typical accurate range is only up to 2 m (10 ft). Note that the only two times the platform will back up is when docking on the docking station, or when the bumper has hit an obstacle. In the latter case, the platform will back up just enough so that it can rotate without touching the obstacle.

#### Front-Facing

The platform's front bumper houses four sonar units, for detecting low obstacles.

### Other Sensors

#### Encoders and Gyroscope

Each wheel has an encoder that tells the navigation system how far the wheel has turned, and in which direction. Each wheel also has a Hall sensor.

The Lynx core has a gyroscope mounted on it, to track the platform's rotation.

The combination of rotation and distance traveled are used by the platform to back up the safety scanning laser during localization. These limit the area on the platform's map that the platform needs to search.

#### Bumper

One bumper, with two pairs of sensors, is mounted at the front of the platform, should the obstacle-avoidance systems fail to detect an obstacle.

Optional user (payload) bumpers can be added using the User Bumper connector on the rear upper core, in the payload bay.

#### Vertical Lasers Option

Two vertically-mounted lasers are available as an option. These are typically mounted on the sides of the payload, to detect objects that protrude into the AIV's path, but but at a height that is not detected by the safety scanning laser, such as shelves that stick out.

### **Acuity Localization Option**

Adept's Acuity Localization uses an upward-facing camera to localize the platform using overhead lights. This can be used in circumstances where laser localization is difficult, either because the environment has too many changing features or simply not enough features for localization. If there are many objects, such as pallets or carts, which change location frequently, they will not show up on a map, and may also block the laser's view of features that are on the map. In such cases, Acuity Localization may be a better choice than using the safety scanning laser for localization.

## **6.7 Startup**

By default, the Lynx core, safety scanning laser, and some auxiliary power start automatically when you press ON. To change that behavior, or to assign AUX power to your own accessories, modify their related parameters from the MobilePlanner software. You can also control power from a client connected with the Lynx core.

### **Networking**

The Lynx core is preset and tested on a Class-C network (netmask for all ports 255.255.255.0). The Maintenance Ethernet port is set to IP address 1.2.3.4 and the wireless IP comes set with an AP-based ("managed") SSID of "Wireless Network", unsecured. Consult with your network systems administrator before modifying these network details through the SetNetGo OS.

The USER LAN port is set to IP address 10.10.10.10.

Refer to the [Adept Motivity® User's Guide](#).





## Chapter 7: Options

---

The Lynx platform is available with a number of options to enhance its performance and abilities.

- The Adept Enterprise Manager is used to manage a fleet of AIVs.

It consists of the ARAMCentral software running on an Adept SmartFleet EX™ appliance. This requires either the Adept Enterprise Manager or Adept Enterprise Manager Lite license.

This is covered in the [Adept SmartFleet EX Appliance User's Guide](#).

- MobilePlanner™ software (licensed)

In order to have your AIV perform autonomous mobile activities, you need to make a map of its operating space, and configure its operating parameters. The MobilePlanner software is used to make this map and perform this configuration.

Refer to the separate [Adept Motivity® User's Guide](#) for details on how to map a working space and prepare the virtual elements, goals, routes, and tasks for your application.

The MobilePlanner software requires a license to run. You need at least one MobilePlanner license for each fleet of AIVs. Once a map is generated, it can be shared with multiple AIVs working in the same space.

- Spare Batteries
- Vertical-mounted Lasers

This is an option for payload development. The two lasers mount on each side of the payload to detect obstacles projecting into the path of the AIV.

This is useful when the payload is tall enough that it might run into obstacles not detected by the safety scanning laser.

The optional vertical lasers connect to the RS-232 Aux Sensors connector on the Lynx core.

- Payload Sonar

This is in addition to the eight standard sonar transmitter/receivers, and includes eight sonar units and a controller, which mounts in the payload bay.

- Light Tower

This complements the light discs, to indicate the AIV's status and movement. Three colors and a buzzer are supported. The light tower behavior is described in Other Controls and Indicators on page 74

- Call Buttons

Call buttons are used to issue a request for a AIV to go to the goal associated with the button. There may be multiple call buttons, even in an installation where there is only one AIV. See [Adept Lynx Platform Peripherals Guide](#).

- Cleanroom version

The platform is available in a cleanroom-suitable version.

- Acuity Localization

This lets the platform localize in dynamic situations where pallets, carts, and other objects are moved frequently, and therefore cannot be used for localization. Acuity Localization uses an upward-facing camera to detect patterns of overhead lights, which it compares with lights stored in its map.

## Chapter 8: Maintenance

This chapter covers periodic maintenance and user-serviceable parts replacement for the Lynx platform and the docking station. It does not cover maintenance of the payload, which is the user's responsibility.

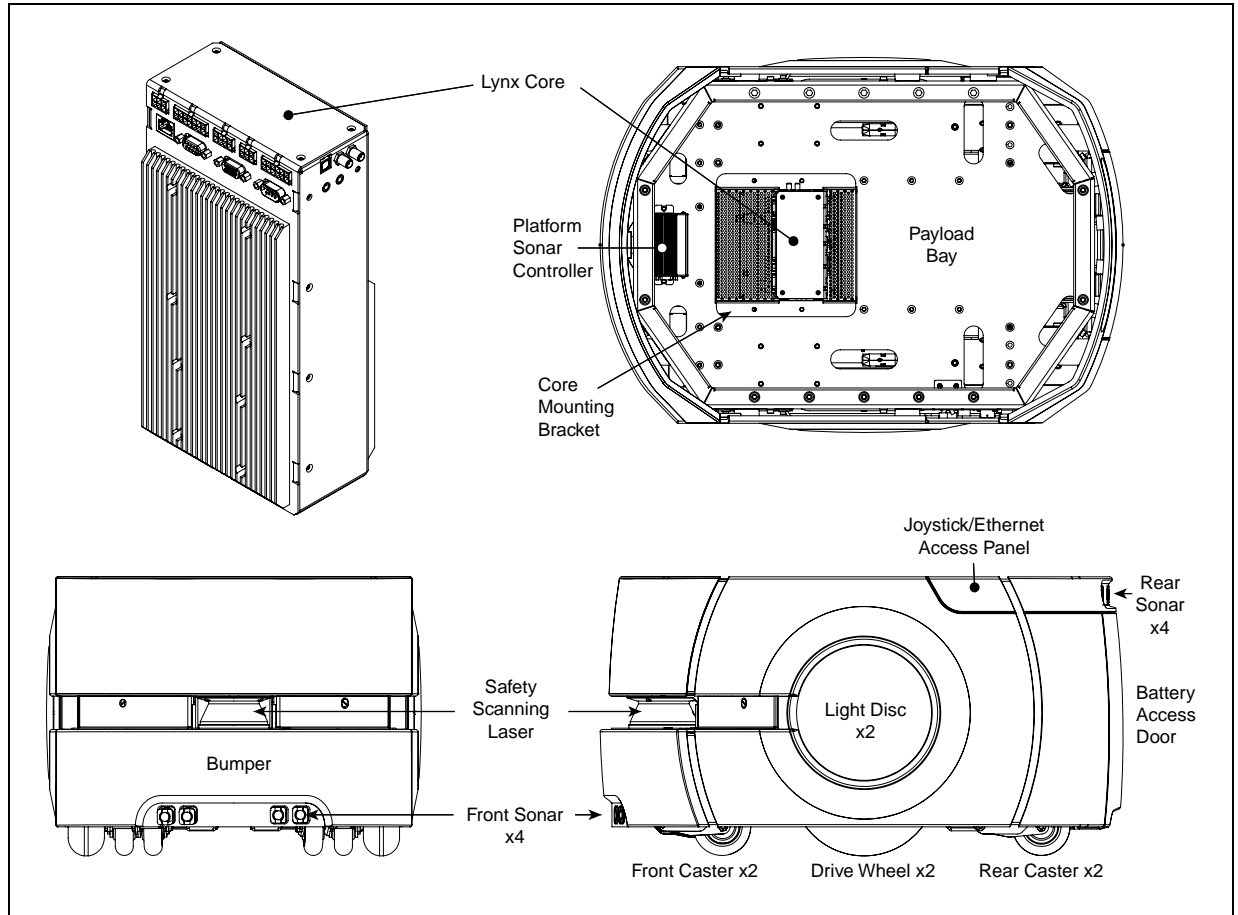

Figure 8-1. Location of Parts on the Platform

## 8.1 Safety Aspects While Performing Maintenance



**DANGER:** During maintenance and repair, the power to the docking station must be turned off. Remove and lock up the power cord to prevent unauthorized third parties from turning on power. The access covers on the docking station are not interlocked.



**DANGER:** Only skilled or instructed persons, as defined in the [Adept Robot Safety Guide](#), should perform the procedures and replacement of parts covered in this section.



**DANGER:** During maintenance and repair of the platform, disconnect the battery as soon as possible. Avoid shorting the terminals of the battery.

## 8.2 Periodic Maintenance Schedule

The drive motors and gearbox are sealed and permanently lubricated, so they do not require periodic maintenance.

### Cleaning

The following table gives a summary of cleaning procedures for the Adept Lynx Platform.

Table 8-1. Cleaning

Item	Period	Reference
Clean docking station contacts	3 months	Docking Station Contacts on page 85
Clean axles and tires	As needed	Tires on page 85
Clean safety scanning laser lens - wipe clean	6 months/ as needed	Lasers on page 85
Clean vertical lasers	6 months/ as needed	Lasers on page 85

**NOTE:** The frequency of these procedures will depend on your particular system, its operating environment, and the amount of usage. Operating in an environment with a lot of dust or dirt will require more frequent cleaning. Use the intervals in this section as guidelines, and modify the schedule as needed.

## Tires

Occasionally clean the tires with a mild soapy solution. Remove any dirt or debris that may accumulate on the tires, because these can degrade the AIV's performance.

This applies to both the drive wheels and to the casters.

## Axles

Keep the axles free of carpet, hair, string, or anything that may wrap around and bind up the platform's drive.

## Lasers

Occasionally clean the lenses of the safety scanning laser and the vertical lasers, if used. Use only alcohol-based, non-abrasive cleaners, and wipe thoroughly.

## Docking Station Contacts

The two docking station contacts occasionally need to be cleaned. The suggested interval is 3 – 6 months, depending on frequency of charging.



**WARNING:** Unplug power from the docking station before starting.

Remove the power cord at the charger.

Clean the contacts with isopropyl alcohol.



**CAUTION:** Do not lubricate the docking station paddle. Lubrication will reduce the life of the paddle.

## 8.3 Accessing the Payload Bay

Access to the payload bay will be dependent on how you have designed your payload. A small, light payload may be easily disconnected and simply lifted off, taking care not to disconnect or damage any of the wires connected to the platform.

A taller or heavier payload should be designed with hinges, so that it can be tilted off of the platform after being mechanically disconnected. For most payloads, this will enable a single technician to access the payload bay without assistance. Care must be taken, when designing the hinges and payload, that the wires and connections between the platform and the payload will not be disturbed when the payload is tilted.

## 8.4 Removing and Installing Covers

Many of the maintenance procedures require removing some of the platform's covers. Most covers are held in place with just magnets. The rear cover has an additional brace for support, the bumper cover uses screws and magnets, and the access panel uses a push-push latch.



**CAUTION:** Pinch hazard. The magnets holding the covers in place are strong enough to pinch you if you are not careful.

**NOTE:** In general, it is better to install the payload first, and then the covers.

The covers are:

- Rear Inner (Battery)
- Access Panel
- Left Side  
Both side covers include a light disc and cover.
- Right Side
- Front Upper
- Bumper
- Rear Outer

With the exception of the bumper cover, no tools are needed for either the removal or installation of the covers.

## Cover Removal

**NOTE:** After removing covers, place them inner-side down, so the outer surfaces don't get scratched.

The covers can be removed in the order in which they are listed above.

- The rear outer must wait for the rear inner and the two side covers.
- The front upper must wait for the two side covers.
- The two sides, the rear inner, and the bumper cover can all be removed without removing any other covers, except that the left cover must wait for the access panel.

**NOTE:** The light disc covers are not covered here because they are only removed from the side covers to replace one of the light disc controllers.

### **Rear Inner Cover (Battery)**

This provides access to the battery compartment door.

1. Pull the bottom of the cover away from the platform chassis.  
This is easiest if you grip it with two hands, toward the center.
2. Lower the cover down, so its top tab clears the rear outer cover.

### **Access Panel**

This provides access to the Maintenance Ethernet and the Joystick ports.

1. Push the left (front) side of the panel in, and the latch will release it.

Pushing the panel a second time will reattach it to the platform.

2. Pull the left side out, and slide the panel to the left.

The panel is attached with a lanyard, to prevent getting lost.

You will need to place this panel out of the way when removing the left side cover.

### **Side Covers**

1. For the left side cover, put the access panel out of the way.
2. Pull the bottom of the cover, near both sides, away from the chassis.
3. Work your way up the edges of the cover, pulling it away from the chassis as you go.
4. Remove the cover a few inches from the chassis.

The light disc wires plug into connectors on the inner side of each side cover.

5. Unplug the light disc connector, and move the side cover away from the platform.

Repeat for the other side cover.

### **Front Upper Cover**

This cover is held onto the chassis the most tightly of any of the covers.

1. Grip the cover at the two outer edges.
2. Pry the cover away from the chassis.

### **Bumper Cover**

This is the only cover that requires tools to remove.

1. Remove the screws at the sides of the cover.

Retain the screws for installing the new bumper cover.

2. Pull the cover off of the bumper.

It is held on with magnets, as well as screws.

### **Rear Outer Cover**

This cover houses the four rear sonar units, which must be disconnected once the cover is part-way off the chassis.

1. Pull the top of the cover away from the chassis a few inches.

The cover will pivot on the metal brace at its bottom edge.

2. Pull the four sonar wires, with their connectors, out of the chassis holes.

Refer to the following two figures.



Figure 8-2. Sonar Leads, with Connectors Still in Chassis

3. Unscrew all four sonar connectors.

Ensure that both sides of all connectors are labeled, and match. If not, label them.

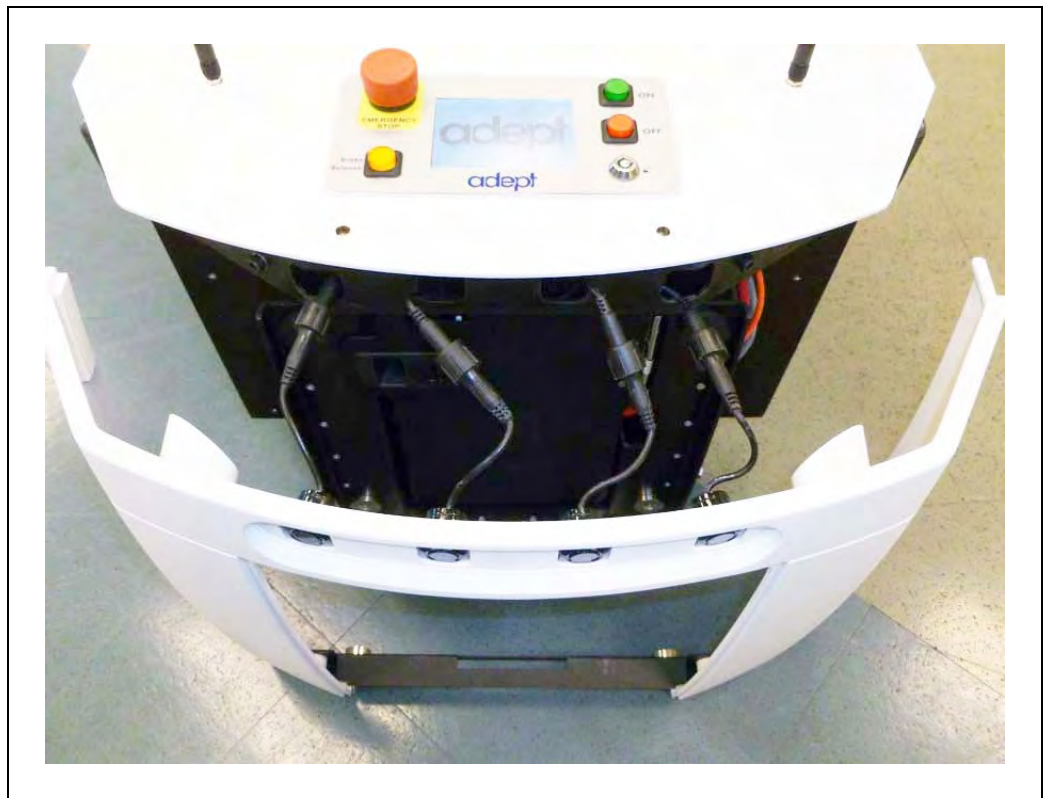

Figure 8-3. Sonar Connectors, with Connectors Exposed



4. Tilt the cover down to about 45°, and slide the brace on the bottom of the cover out of its clip.

This will separate two pairs of magnets, so you will feel some resistance at first.

## **Cover Installation**

The covers can be installed in the reverse of the order in which they are listed above.

- The front upper and rear outer covers must be installed first and second.
- The access panel must wait for the left side cover.

### **Bumper Cover**

This is the only cover that requires tools to install.

1. Place the cover on the bumper.  
It is held on with magnets, as well as screws.
2. Install the screws, removed during the cover removal, at the sides of the cover.

### **Front Upper Cover**

1. Grip the cover at the two outer edges.
2. Align the bottom edge of the cover so it slides under the chassis support.
3. Tilt the top of the cover into position.

### **Rear Outer Cover**

This cover houses the four rear sonar units, which must be reconnected once the metal brace across the bottom is in the clip just below the battery access hole.

1. Slide the metal brace into the clip in the chassis.  
Watch the two magnets on the bottom of the cover, to align them with their mating magnets on the chassis. This is your best guide for getting this cover in its proper place.  
These are inboard of the clip holding the brace, so you will have to look on each side of the cover to check their alignment.
2. When the magnets at the bottom are lined up, tilt the cover up to within a few inches of the chassis.
3. Pull the sonar connectors out of the chassis, if they are not already out.
4. Screw the four sonar connectors to their corresponding sonar leads.  
Ensure that the labels for the connectors and leads match.
5. Tuck the connectors into the four holes in the chassis, until just an inch of sonar lead is sticking out.
6. Tilt the top of the cover up to meet the chassis.

### Side Covers

1. Move the cover to within a few inches of the chassis, and plug in the light disc connector.

The light disc is connected to a connector, accessible on the inner side of the side cover.

2. Place the top edge of the cover on the chassis, so the magnets hold it there.

Make sure the gaps on each side of the cover are the same width.

3. Tilt the bottom edge of the cover down.

4. Check each side of the cover to ensure that the cover edges on each side of the gap stick out the same amount away from the chassis.

This is most likely to be uneven near the top of the cover.

5. If either edge sticks out more than the neighboring cover, pull the neighboring cover away from the side cover slightly, and release.

This should allow the side cover to snap into place, so both sides of the gap stick out the same amount.

Repeat for the other side cover.



Figure 8-4. Right Side Cover, Showing Even Gaps at Edges

**NOTE:** The gaps between the side covers and the bumper cover will be smaller than the other gaps, and will not be even.

### Access Panel

1. Slide the panel to the right, so its tab goes under the left side cover.

The panel is attached with a lanyard, to prevent getting lost.

2. Press the left (front) side of the panel in, and the latch will hold it.

This is a toggle latch - pressing it once engages it, pressing it a second time releases it.

### **Rear Inner Cover (Battery)**

1. Slide the cover up, so its top tab fits under the rear outer cover.



**CAUTION:** Pinch hazard. This cover is the most likely to pinch you if you are not careful, particularly at its bottom edge. Hold the cover at the bottom, in the center, with two hands.

2. Holding the cover near the center, with both hands, tilt the bottom of the cover down, towards the platform chassis.

## **8.5 Replacing Periodic Parts**

### **Battery**

The battery is expected to last for approximately 7 years of 16 hours/day, 5 days/week. Life expectancy for 19/7 is 4 years. (19 hours/day is full-time, with time-out to recharge.)

**NOTE:** There are no serviceable parts inside the battery case. Do not open it.



**WARNING:** Replace the battery only with an Adept battery.

Dispose of the battery according to all local and national environmental regulations regarding electronic components. Refer to:

<http://www.adept.com>, under Contacts.



**DANGER:** Follow appropriate ESD procedures during the removal/replacement phases.

Before removing or installing a battery, remove the rear inner platform cover. Refer to Removing and Installing Covers on page 85.

### **Removal**



**WARNING:** The battery is heavy (20 kg/44 lbs). Observe safe lifting practices when removing or installing the battery.

1. Unlatch and open the battery compartment door, at the back of the platform.  
The battery compartment door is capable of being locked. You may need to unlock it before opening.
2. Disconnect the power and data cables before removing the battery.  
See the following figure.

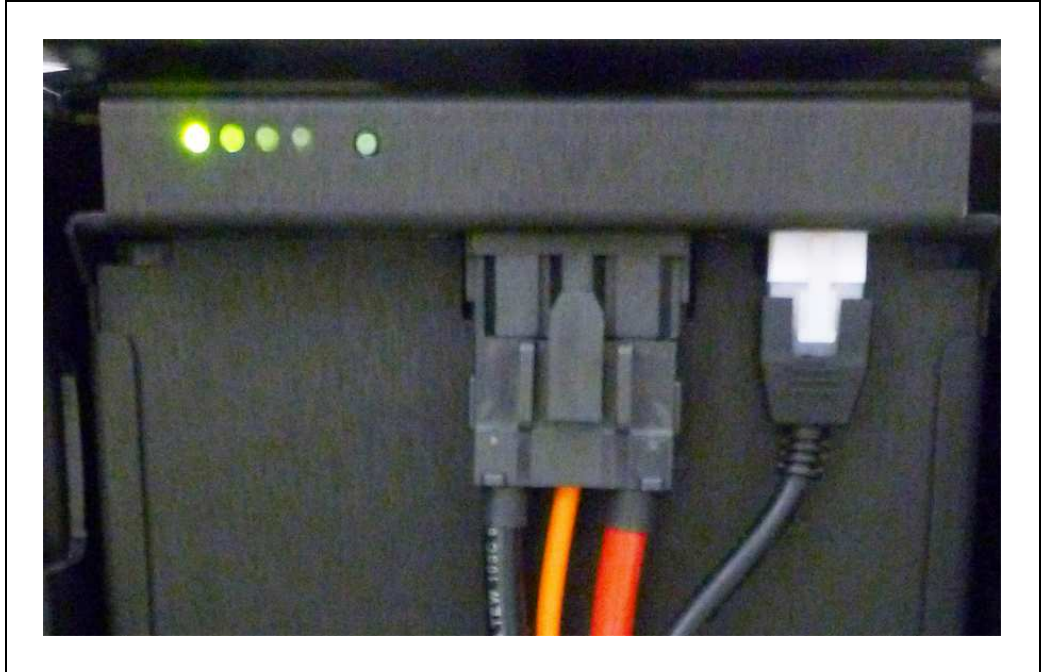

Figure 8-5. Battery Power and Data Cable Connectors

3. Slide the battery back and out of the platform.  
There is a hand grip at the front and the rear of the battery, to help you lift it.

### **Installation**

Refer to Removing and Installing Covers in the Maintenance section for cover removal and installation.

1. Remove the inner rear platform cover.
2. Unlatch and open the battery compartment door, at the back of the platform.  
The battery compartment door is capable of being locked. You may need to unlock it.



Figure 8-6. Battery Compartment Door (keys are zip-tied for shipping)

3. Lift and slide the new battery into the platform body.

The battery weighs 20 kg (44 lbs).

There are recesses at the front and the back of the battery, to aid in lifting it.



Figure 8-7. Battery Recesses, for Gripping

The battery is designed to be lifted and replaced by one person, using one hand in each of the grips, as shown in the following figure.



Figure 8-8. Lifting the Battery

The connectors for power and data go toward the rear of the platform.

4. Attach the battery power and data cables to the connectors at the rear of the battery.
5. Close the battery compartment door to secure the battery in place.

The battery compartment is designed to hold the battery tightly, so that it will not move within the compartment, once the door is closed.

6. Reinstall the inner rear platform cover.

## 8.6 Replacing Non-Periodic Parts

All of the following parts are replaced on an as-needed basis.

### Docking Station Roller and Bearing

The roller, which guides the AIV onto the docking station, may be subject to wear after extended use. The time to replace the roller should be based on your visual inspection and judgment of when it is too worn. Adept does not specify a quantitative measure for this.

Refer to the following figure for the location of the roller.



**WARNING:** Unplug power from the docking station before starting.

Remove the power cord at the charger.

The roller is held to the docking station with a shoulder bolt.

1. Remove the shoulder bolt from the center of the roller. Retain the shoulder bolt.
2. Remove the roller and bearing from the docking station.

3. Install the new roller and bearing, using the retained shoulder bolt.



Figure 8-9. Docking Station Roller and Fuse Locations

### Docking Station AC Power Fuse

The only user-serviceable fuses are in the docking station. The two external AC fuses are located between the power switch and the AC power plug.

Symptoms: When the docking station is switched on, the blue power light does not come on. (Verify that the unit is plugged into AC power.)



**WARNING:** Unplug power from the docking station before starting.

Remove the power cord at the charger.

The fuse assembly can be removed by squeezing the two tabs toward each other, and pulling it away from the docking station. The fuses are p/n 04563-000. See the following figure.

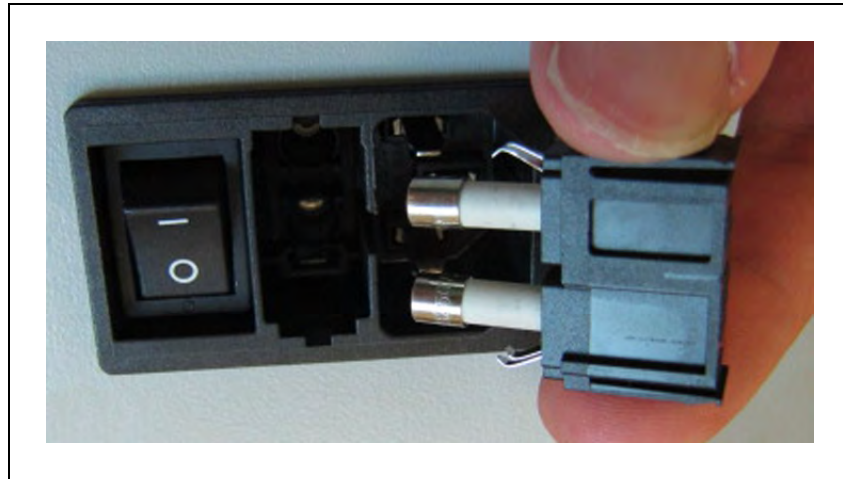

Figure 8-10. Docking Station Fuse

### Docking Station Internal Fuse

Symptoms: When the docking station is switched on, the blue power light does not come on, but the docking station can charge a battery manually.



**WARNING:** Unplug power from the docking station before starting.

The docking station cover is NOT interlocked. Remove the power cord at the charger.

1. Remove the ten screws from the back cover of the docking station.

Two of these are on the sides, near the bottom.



Figure 8-11. Docking Station Rear Cover Screws (8 of 10)



Retain the screws for reassembly.

2. Remove the rear cover of the docking station.
3. Locate the in-line fuse.

It will be near the top of the docking station, just to the right of the central terminal bar.

4. Remove the old fuse, and replace it with a new fuse.

The fuse is p/n 13091-000.

5. Reinstall the docking station rear cover, and secure with the ten screws previously removed.

### Rear Sonar Units

The platform's four rear sonar units can be replaced individually.

1. Remove the inner and outer rear covers from the platform. Refer to Removing and Installing Covers on page 85.
2. Unscrew the connection between the sonar cable and the sonar unit's lead.  
Ensure that both the connectors and leads are labeled, and match. If not, label them.
3. Compress the two flat springs holding the sonar unit, and remove it from the cover.
4. Press the new sonar unit through the hole in the rear outer cover, from the outside.
5. Connect the sonar cable to the new sonar unit's lead.
6. Reinstall the rear covers.

### Front Sonar Units

The front sonar units are housed in the bumper. They can be replaced, individually, without removing the bumper or its cover. No tools are required for this replacement.

1. Reach under the bumper cover, and compress the two flat springs holding the sonar unit.  
Push it out of the bumper cover, away from the chassis, to remove it from the cover.
2. Unscrew the connection between the sonar cable and the sonar unit's lead.  
Ensure that both the connector and lead are labeled, and match. If not, label them.
3. Connect the sonar cable to the new sonar unit's lead.
4. Tuck the cable and lead through the sonar unit's hole in the bumper cover, and press the new sonar unit through the hole, from the outside.

### Sonar Controllers

The sonar controllers are located in the payload bay. One is used for the standard front/rear sonar. A second controller is only present if you purchased the optional payload sonar kit.

1. Move the AIV payload out of the way, so you have access to the payload bay.
2. Locate the sonar controller that you need to replace.

#### Payload sonar controller

- The payload sonar controller is plugged into the Sonar 2 connector on the Lynx core. This connector is accessible from the payload bay.
- The controller will be on one side of the payload bay, screwed into the payload bay deck with two screws.
- a. Unscrew the controller from the payload bay deck by removing two screws.  
Retain the screws for mounting the replacement controller.
- b. Unplug the larger cable from the controller (coming from the Lynx core).
- c. Unplug the eight sonar units from the sonar controller.  
These are the smaller cables that go to the individual sonar units.  
Make sure these are labeled, and are tied up so they can't slip into the chassis.
- d. Replace the old controller with the new one.
- e. Plug the eight sonar unit cables into the new controller.  
Ensure that the cable labels match the controller labels.
- f. Plug the cable from the Lynx core into the new controller.
- g. Screw the new controller to the payload bay deck, using the two screws you removed from the old controller.

#### Platform sonar controller.

- This controller is plugged into the Sonar 1 connector on the Lynx core. This connector is not accessible from the payload bay, but does not need to be unplugged for this procedure.
- The controller will be at the very front of the payload bay, screwed into the payload bay deck with two screws.
- a. Unscrew the controller from the payload bay deck by removing two screws.  
Retain the screws for mounting the replacement controller.
- b. Unplug the larger cable from the sonar controller.  
Be careful not to let the cable end slip into the chassis.
- c. Unplug the eight sonar unit cables from the controller.  
These are the smaller cables that go to the individual sonar units.  
Make sure these are labeled and tied up, so they can't slip into the chassis.
- d. Remove the controller from the payload bay, and replace it with the new one.
- e. Connect the eight sonar unit cables to the new controller.  
Ensure that the cable labels match the controller labels.
- f. Plug the larger cable into the new controller.

- g. Screw the new controller to the payload bay deck, using the two screws removed from the old controller.
3. Reinstall the payload.
4. Dispose of the old controller according to local and national regulations concerning electronic components.

## Light Discs

The two light disc assemblies and their controllers are single units, so replacing a controller also replaces all of the lights on that side of the platform.

1. Remove the side cover, on the side that needs the light disc assembly replaced.  
Refer to Removing and Installing Covers on page 85.
2. Unscrew the four screws holding the light disc PCA to the side cover.  
Retain the screws and round cover for installing the new assembly.
3. Remove the light disc PCA.
4. Screw the new assembly and retained round cover to the side cover, using the screws retained from the old assembly. The PCA is keyed so that it can only be installed in one orientation.
5. Reinstall the side cover, connecting the cable to the new light disc PCA.
6. Dispose of the old light disc PCA according to local and national regulations concerning electronic components.

## Operator Panel

The Operator panel will typically be located on a user-supplied payload, so the removal and replacement of this will vary from one AIV to another. It plugs into the HMI Panel connector on the Lynx core.

## Drive Assemblies

The platform drive assemblies have been designed to be field-replaceable. This will replace the drive motor, gearbox, encoder, and wheel/tire assembly.

### Removal

1. Remove the inner rear cover.
2. Unlatch and open the battery compartment door, at the back of the platform.  
The battery compartment door is capable of being locked. You may need to unlock it before opening.
3. Disconnect battery power by unplugging the two cables at the rear of the battery.
4. Remove the side cover a small distance from the platform on the side where you want to replace the drive assembly. Refer to Removing and Installing Covers on page 85.

The light disc PCA cable will still be attached.

5. Disconnect the cable from the light disc PCA, so the side cover can be moved completely away from the platform.

This will expose the drive assembly.

6. Lift the drive wheel up, compressing its springs, enough so that you can insert a  $\text{Ø } 6 \times 10 \text{ mm}$  ( $\text{Ø } 0.24 \times 0.4 \text{ in.}$ ) pin into the hole on the rear side of the assembly (there is a hole on each side). This will keep the springs compressed (the wheel will be in the up position), and make removal easier. An M5 x 10 screw works well for this.

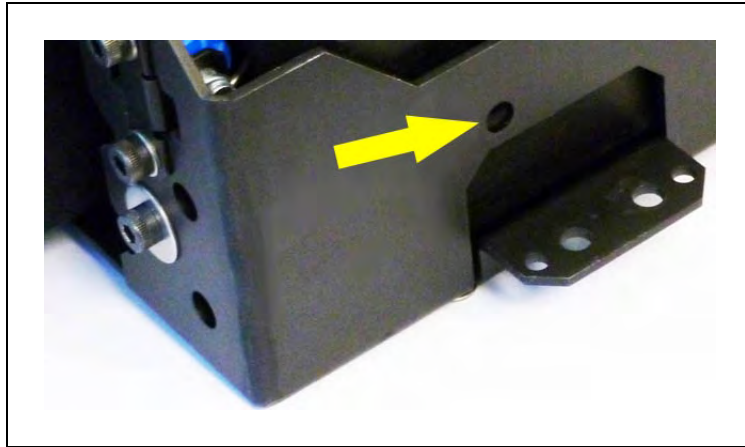

Figure 8-12. Spring-Compression Hole

7. The drive assembly is held in place with three nuts on studs across the top, and two sets of two screws at each side, near the bottom of the assembly.

Remove the three nuts and four screws (and their washers) holding the drive assembly to the platform.

Retain these nuts, screws, and washers for attaching the new drive assembly.

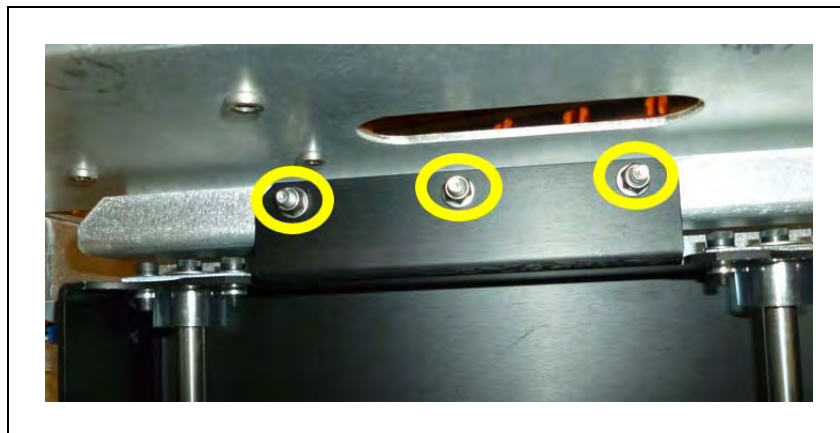

Figure 8-13. Mounting Studs and Nuts at top of Drive Assembly

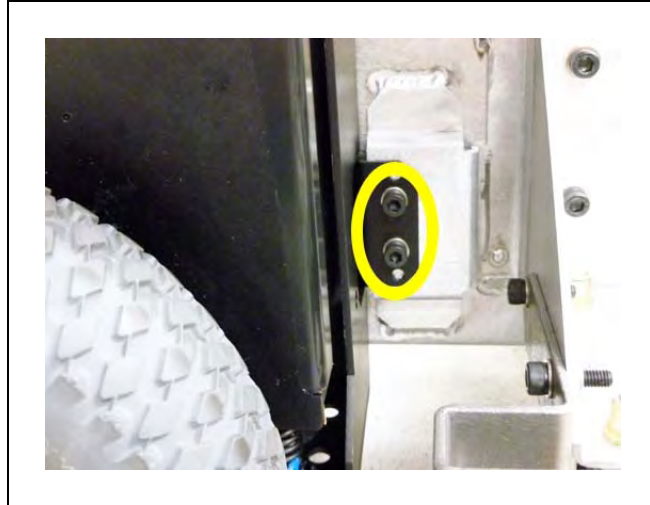

Figure 8-14. Mounting Screws at Bottom-Right of Drive Assembly

8. Remove the drive assembly from the platform.  
The motor cable to the Lynx core will still be attached.
9. Disconnect the motor cable at the drive assembly.

### **Installation**

1. Compress the springs of the new drive assembly by pushing the drive wheel up. When it is in the up position, insert a  $\text{Ø } 6 \times 10 \text{ mm}$  ( $\text{Ø } 0.24 \times 0.4 \text{ in.}$ ) pin into the rear hole on the side of the assembly. There is a hole on each side.

**NOTE:** Make sure that the pin is short enough so that you can pull it out after the assembly is in place. An M5 x 10 screw works well for this.

2. Connect the motor cable to the new drive assembly.
3. Install the new drive assembly over the three studs at the top of its bracket.
4. Attach the drive assembly to the chassis with three nuts at the top, and two screws at each side, near the bottom.  
Use the nuts, screws, and washers you removed from the old drive assembly.
5. Remove the pin or screw you used to hold the wheel in the up position.
6. Put the side cover next to the platform, and attach the light disc cable to the light disc PCA.
7. Reinstall the side cover.
8. Connect the battery power and data cables, and close the battery compartment door.
9. Reinstall the rear cover.

### **Front or Rear Casters**

All four casters are identical, and are mounted to the platform in the same way.

**NOTE:** If you have a means to lift the chassis of the platform enough to access the screws that hold on the caster, you can avoid removing the payload and the battery, which are only necessary to tilt the platform on its side.

1. Move the payload out of the way.  
If the payload can be completely removed, do so. This step is to enable you to tip the Lynx AIV on its side, so you have access to the casters underneath.
2. Remove the inner rear cover.
3. Unlatch and open the battery compartment door, at the back of the platform.  
The battery compartment door is capable of being locked. You may need to unlock it before opening.
4. Disconnect the battery by unplugging the two cables at the rear of the battery.
5. Remove the battery from the platform.
6. Remove the side covers.
7. Lay the body of the platform on its side, exposing the casters.
8. Remove the four screws holding the caster to the platform.  
Retain these screws for attaching the new caster.



Figure 8-15. Rear Caster Attachment

9. Remove the caster from the platform.
10. Attach the new caster with the four screws you removed from the old caster.

**NOTE:** The caster bearing is not centered on the sheet metal that it attaches to. The caster needs to be mounted as far from the center of the platform as possible.

11. Return the platform to its upright position.
12. Reinstall the battery, connect the power and data cables, and close the battery compartment door.
13. Reinstall the inner rear cover.
14. Reinstall the side covers.
15. Reinstall the payload.

### **Safety Scanning Laser**

1. While supporting the laser, unscrew the two screws and washers from the bracket holding the laser, to remove the laser from the platform chassis.

Retain these screws and washers for installing the new laser.

2. Unscrew the four screws holding the black plate on top of the laser.

Retain the four screws for reassembly.

You will use this top cap on the new laser. Do not unplug it from the platform chassis.



Figure 8-16. Safety Scanning Laser



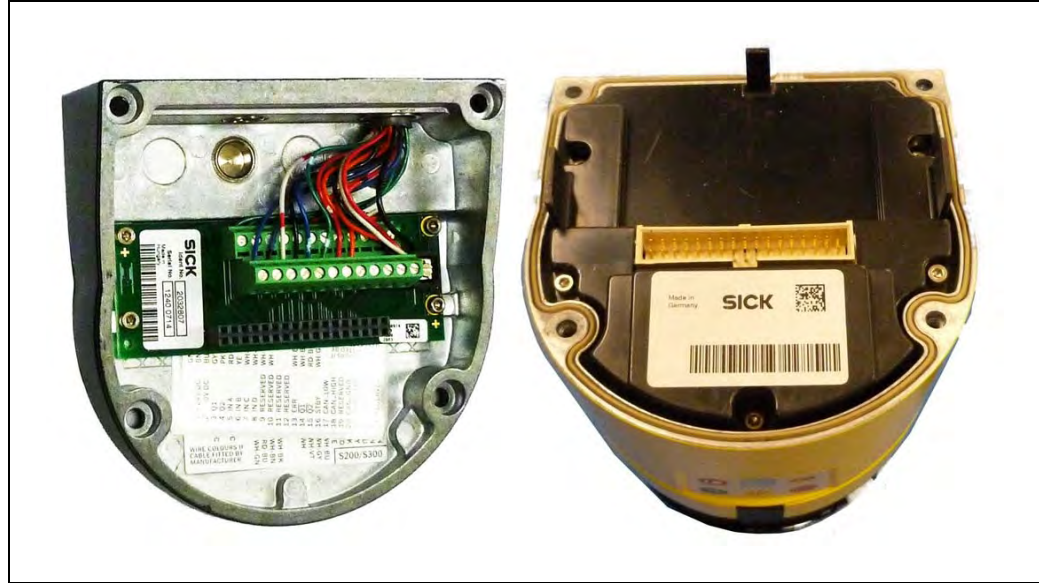

Figure 8-17. Connectors Inside Laser Cap

The underside of this plate has a connector that makes an electrical connection with a mating connector inside the laser.

3. Put the existing laser top onto the top of the new laser.  
You will feel slight resistance as the two connectors plug into each other.
4. Connect the black top plate to the new laser, using the four retained screws.
5. Attach the laser to the chassis using the two screws and washers from the old laser.

**NOTE:** The laser orientation can be adjusted. Be careful to mount the laser horizontal with respect to the floor.

## Lynx Core

The Lynx core is a sealed unit, with internal fans as the only moving parts.

1. Move the AIV payload out of the way, so you have access to the payload bay.
2. Remove the inner rear cover.
3. Unlatch and open the battery compartment door, at the rear of the platform.  
The battery compartment door is capable of being locked. You may need to unlock it.
4. Disconnect the battery power and data cables from the rear of the battery.
5. Disconnect all of the cables that are attached to the top portion of the Lynx core.  
Refer to Payload Bay Connections on page 47.
6. Remove the core mounting bracket from around the Lynx core.

This is two pieces, held in place with four screws down into the chassis, with four more going sideways into the Lynx core itself. Retain all of these screws for installing the new Lynx core.

See the following figure:

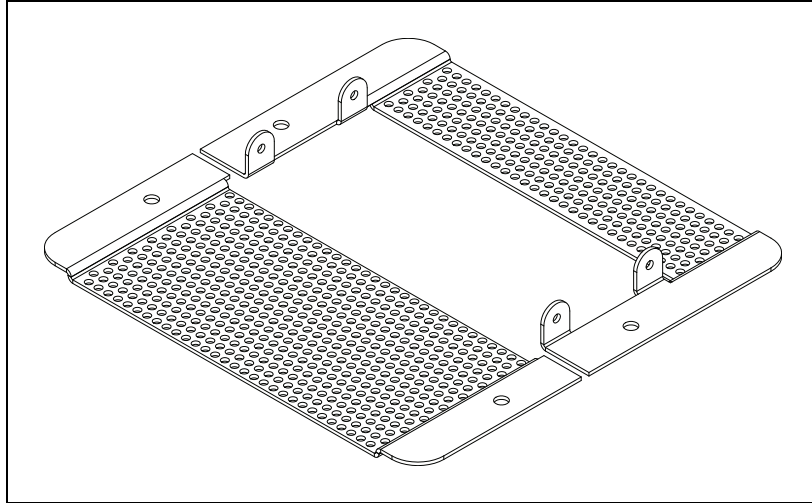

Figure 8-18. Core Mounting Bracket

7. Remove the Sonar 1 cable from the core.  
This cable is too short to allow the core to be lifted, until the cable is removed.
8. Gently lift the Lynx core up, until you have access to the internal connections.
9. Remove all of the cables that are attached to the internal Lynx core connector panel.  
The Left Motor and Right Motor connectors use the same type of plug, and can be inadvertently reversed. Ensure that you can identify the left from the right.  
See Internal Lynx Core Connections on page 61.
10. Remove the old Lynx core.
11. Connect all of the cables that were attached to the internal Lynx core connector panel to the new core internal connector panel. See Figure 5-7.  
Wait until after the next step to reconnect the Sonar 1 cable.
12. Put the core into the chassis.
13. Connect the Sonar 1 cable to the core.
14. Install the core mounting brackets around the new Lynx core.  
Using the screws and washers you removed from the old core, put four screws into the sides of the Lynx core, with four more going down into the platform chassis.
15. Reconnect all of the cables to the top portion of the Lynx core.  
Refer to Payload Bay Connections on page 47.
16. Reconnect the battery power and data cables to the battery.

17. Close and latch the battery compartment door.
18. Reinstall the inner rear cover.
19. Reinstall the payload.
20. Dispose of the old core according to local and national regulations concerning electronic components.

### **E-Stop and Safety Laser Commissioning**

Under normal circumstances, the Lynx AIV is commissioned at the Adept factory, and will not need to be re-commissioned. However:

- If the core gets replaced, it will be necessary to redo the E-Stop Commissioning and the Safety Laser Commissioning procedures.
- If the hardware detects a failure, the AIV may automatically decommission itself, and the AIV will have to be re-commissioned to recover. In this event, ARAM will display a fault popup in MobilePlanner.
- Some customers have expressed a desire to perform the commissioning procedures on a regular basis as part of their preventive maintenance process.

**NOTE:** After performing either of these tests, you can access the other test by clicking Next Test on the final screen.

#### ***E-Stop Commissioning***

This procedure verifies that the E-Stop circuitry is triggered when the E-Stop button is pressed. This is verified by ensuring that you hear the brakes activate after pressing the E-Stop button.

1. Ensure that the E-Stop button is NOT depressed before starting.
2. From the MobilePlanner software, select:  
**Main Menu > Robot > Safety Commissioning**
3. Follow the on-screen instructions to complete the test. You can print a certificate after successful completion of the commissioning.

#### ***Safety Laser Commissioning***

This procedure verifies that the safety scanning laser reports speed zone information correctly, and that the E-Stop circuitry is tripped when an obstacle that should be detected by the laser is placed in front of the AIV. Each speed zone represents 300 mm/sec, so if the maximum speed is 1500, five zones should be reported. (When you press the Drive button in the wizard, the wizard will display the maximum AIV speed.)

1. From the MobilePlanner software, select:  
**Main Menu > Robot > Safety Commissioning**
2. Follow the on-screen instructions to complete the test. You can print a certificate after successful completion of the commissioning.

## 8.7 Spare Parts List

Part Number	Description
Bundles, Major Components	
99060-000	Bundle, Adept Lynx Main bundle (Lynx, Dock. Station, Joystick, software)
59060-000	Assembly, Adept Lynx Top assembly (just the Lynx)
12907-000	Assembly, Joystick
11700-000	System, Adept Lynx Core
Docking Station, Docking	
12477-000	Docking Station (Dock)
13091-000	Fuse, 1 A, 3AG (¼ x 1¼), Internal Docking Station fuse
04563-000	Fuse, 8 A, 5 x 20 mm, External Docking Station fuses, x 2
12438-000	Fuse Drawer, 5 x 20 mm, Docking Station power entry side
12416-000	Roller, Docking Station
12417-000	Contact, Paddle, Docking Station (x 2)
12872-000	Assembly, Frame, Docking Funnel
Covers, Latches	
12804-100	Cover: bumper (lower front)
12804-200	Cover: front (upper front)
12804-350	Cover: Right panel + light disc
12804-450	Cover: Left panel + light disc
12804-600	Cover: Hatch (Access Panel to Maint. Ethernet, Joystick)
12855-000	Push Latch, 3 kg retaining force, Black (Access Panel latch)
12804-700	Cover: Rear
12804-800	Cover: Battery door
12168-000	Latch, locking, flush, ABS Battery latch (contains the key)
Operator Panel	
12800-000	Assembly, HMI Panel
12410-000	Push Button, Green, Panel Mount, Round
12411-000	Push Button, Red, Panel Mount, Round
12412-000	Push Button, Yellow, Panel Mount, Round
12413-000	Switch, Keylock, 2 Keypull Positions, 90° (contains HMI key)

Part Number	Description
Sonar, Laser	
11711-000	Assembly, Sonar Controller
11714-000	Sensor, Piezo Ultrasonic, 40 KHz, with Cable (Sonar Units x 8)
12170-000	Safety Laser, S300, Expert, 270 Degree
12718-000L	Cable, SICK LIDAR Laser
Suspension, Drive, and Battery	
12745-000	Assembly, Right Drive Train
12746-000	Assembly, Left Drive Train
12072-000	Assembly, Battery
12150-000	Casters, Shock Absorbing, Absorbing Pad 87, Shore A
Miscellaneous	
12330-000	Speaker, 3.5 in., 80 W
12312-000	Micro Switch, Positive Opening Contacts (Front Bumper x 4)
12730-000L	Jumper, User ESTOP



# Chapter 9: Technical Specifications

## 9.1 Dimension Drawings

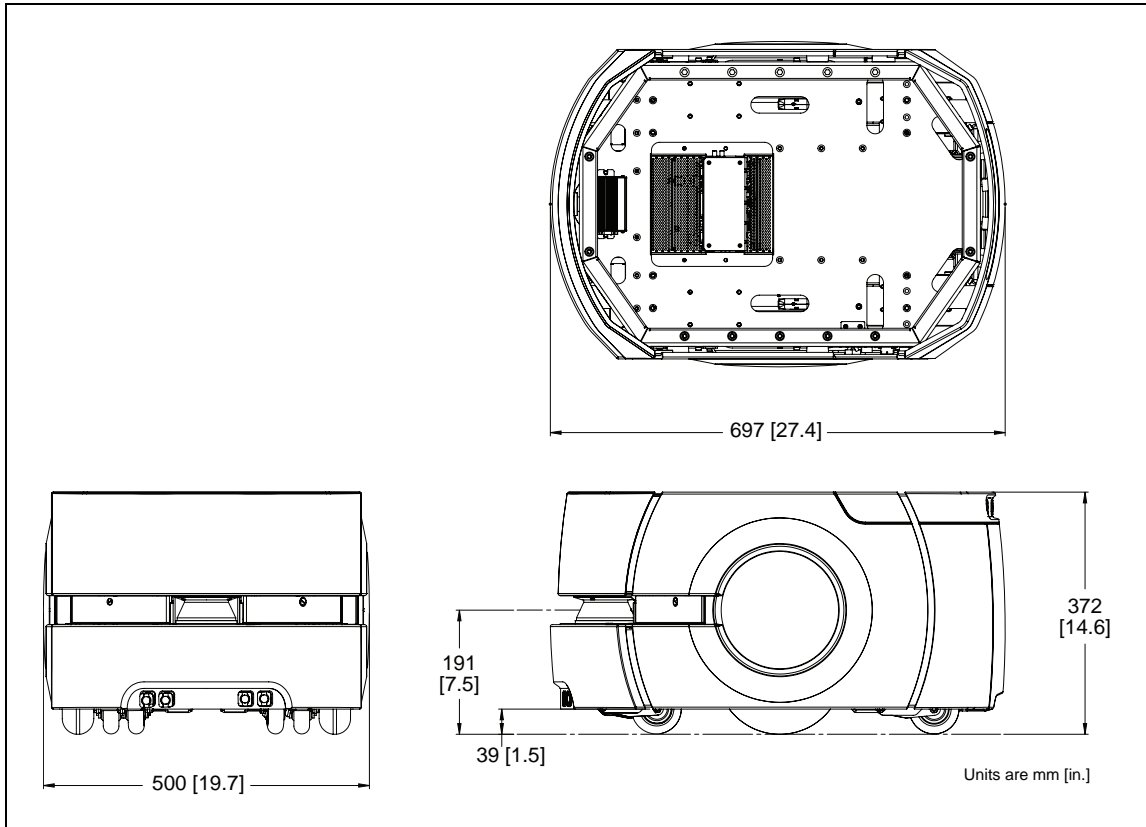

Figure 9-1. Adept Lynx Platform Top, Side, and Front Dimensions

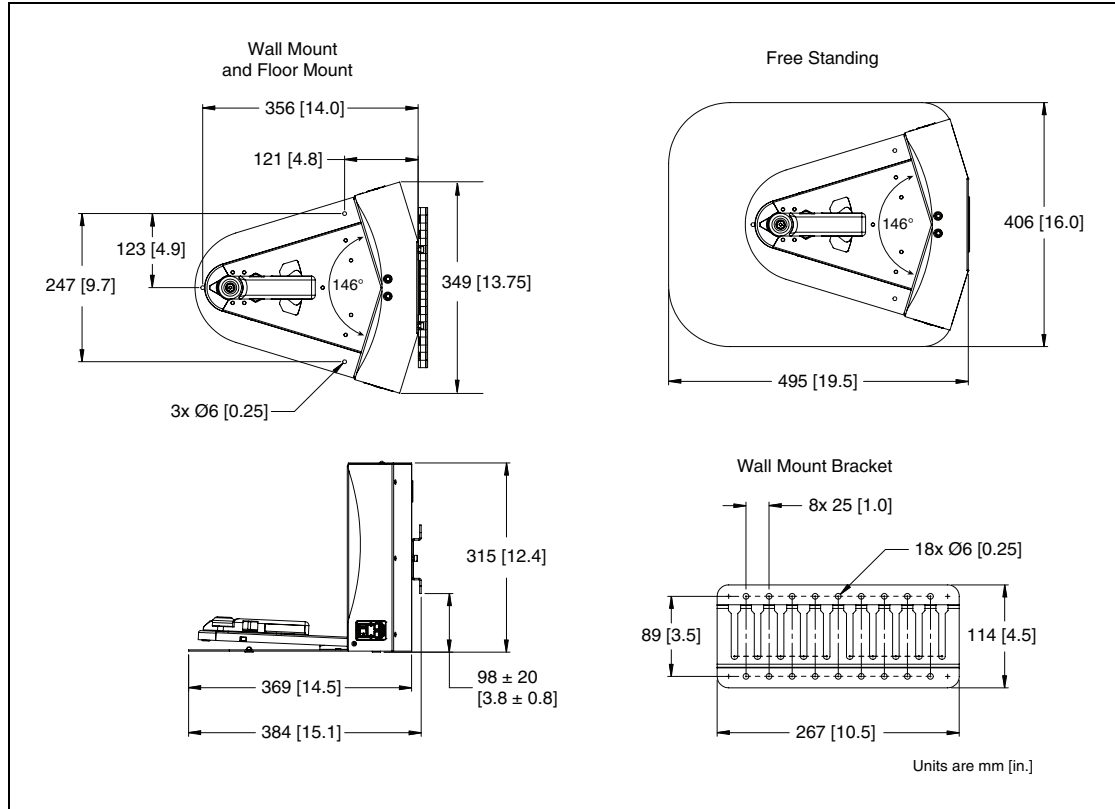

Figure 9-2. Docking Station Dimensions

## 9.2 Platform Specifications

Description	Specification
<b>Physical - platform only</b>	
Length	686 mm (27 in.)
Width	483 mm (19.0 in.)
Height (body)	371 mm (14.6 in.)
Body clearance	38 mm (1.5 in.)
Weight (with battery)	60 kg (132 lb)
<b>Rating</b>	
IP Rating	IP-44
Cleanroom rating	Fed Class 100, ISO Class 5
<b>NOTE:</b> Fed Class 10 (ISO Class 4) is attainable in many cases. Contact Adept.	
<b>Drive Train</b>	
Drive wheels	2 grey non-marking foam-filled rubber



Description	Specification
Wheel diameter	200 x 50 mm (7.9 x 2.0 in.) nominal)
Passive Casters	2 front, 2 rear, spring-loaded
Brakes	2 (one each axle)
Steering	Differential
Gear ratio	30:1

Description	Specification
<b>Performance</b>	
Max payload weight – level	60 kg (132 lb)
Swing radius	343 mm (13.5 in.)
Turn radius	0 mm
Translational speed, max	1800 mm/sec (67 in./sec)
Rotational speed, max	300 degrees/sec
Traversable step, max	15 mm (0.6 in.)
Traversable gap, max	15 mm (0.6 in.)
Climb grade	1:12
Traversable terrain	All wheelchair accessible
<b>Battery</b>	
Run-time	13 hours, approx., no payload
Duty cycle	80%
Weight	20 kg (44 lb)
Voltage	22 - 30 VDC
Capacity	60 Ah
Energy	1.5 kWh nominal
Recharge time	3.5 hours, approx.
Life span	7 years, approx., 16 hrs/day, 5 days/wk 4 years, approx., 19/7 (full-time)
<b>Sensors</b>	
Safety Scanning Laser	1 at front of platform, 191 mm (7.5 in.) height 250°, 15 M range, Class 1, eye-safe PLd Safety per ISO-13849

Description	Specification
Sonar	4 at rear of platform, 2 M range 4 at front of platform, in bumper, 2 M range
Position encoders	2 x 512 quadrature (one each wheel) 2 x Hall sensors
Analog gyroscope (Lynx core)	320 degree/sec max rotation
Bumper	1 at front of platform, 2 pairs of sensors
Vertical Lasers (option)	2 on sides of payload, user-mounted
Upward-facing camera (Acuity)	1 on payload, user-mounted
Payload Sonar Sensors (option)	8 available, user-mounted

### 9.3 Docking Station Specifications

Description	Specification
Current	8 A 8 A fuse at power plug/switch
Contacts	2
Voltage	100 to 240 VAC, 50 to 60 Hz
Power consumption	800 W
Short circuit current rating (SCCR)	1500 A
Humidity	5 to 95% non-condensing
Temperature	5° to 40° C (41° to 104° F)
Dimensions - WxDxH with Floor plate	349 x 369 x 315 mm (13.75 x 14.5 x 12.4 in.) 495 x 495.5 x 317 mm (16 x 19.5 x 12.5 in.)
Weight	8.2 kg (18 lbs)
Mounting	Wall bracket, directly to floor, or on floor with floor plate
Indicators	Power on - blue Charging - yellow
Connector	For out-of-platform battery charging





5960 Inglewood Drive  
Pleasanton, CA 94588  
925-245-3400

P/N: 11970-000 Rev B